

# CONTENTS

# 目錄

1	Installation	安裝
1.1	Table dimensions	桌板尺寸
1.2	Adjusting presser foot lift	調整抬壓腳
1.3	Other Parts	其它部份
2	Sewing speed and rotating direction	馬達轉速和轉動方向
3	Lubrication	潤滑
3.1	Lubrication oil	潤滑油
3.2	Lubricating	潤滑系統
3.3	Priming oil	啟動注油
3.4	Replenishing oil	補充油
3.5	Changing oil	更換油
4	Proper operation	使用說明
4.1	Needle system	車針系列
4.2	Installing needle	針的安裝
4.3	Threading	線
4.4	Thread tension	線鬆緊
4.5	Pressure of presser foot	調整壓腳壓力
4.6	Up-and-down position of presser foot	調整壓腳高低
4.7	Adjusting differential feed dog	調整差動
4.8	Adjusting stitch length	調整針距
4.9	Adjusting lapped width of upper fabric	調整切布刀
4.10	Sp device	過線油組
4.11	Use of lap former	導布器
5	Adjustments	調節裝置
5.1	Needle thread tension	針線鬆緊
5.2	Looper thread tension	下底線
5.3	Top cover thread tension	上網線
5.4	Height of needle	針位高度
5.5	Top cover thread carrier and hook	上勾針
5.6	Looper	下勾針
5.7	Needle guard (front)	前針檔
5.8	Needle guard (rear)	後針檔
5.9	Height of feed dog	狗齒高度
5.10	Replacing presser foot	置換壓腳
5.11	Replacing presser foot spring plate	置換壓腳彈簧片
5.12	Replacing and adjusting knives	置換和調整位置
6	Specifications	規格

# 1 · Installation 安裝

## 1.1 桌板尺寸

## 1.1 Table dimensions

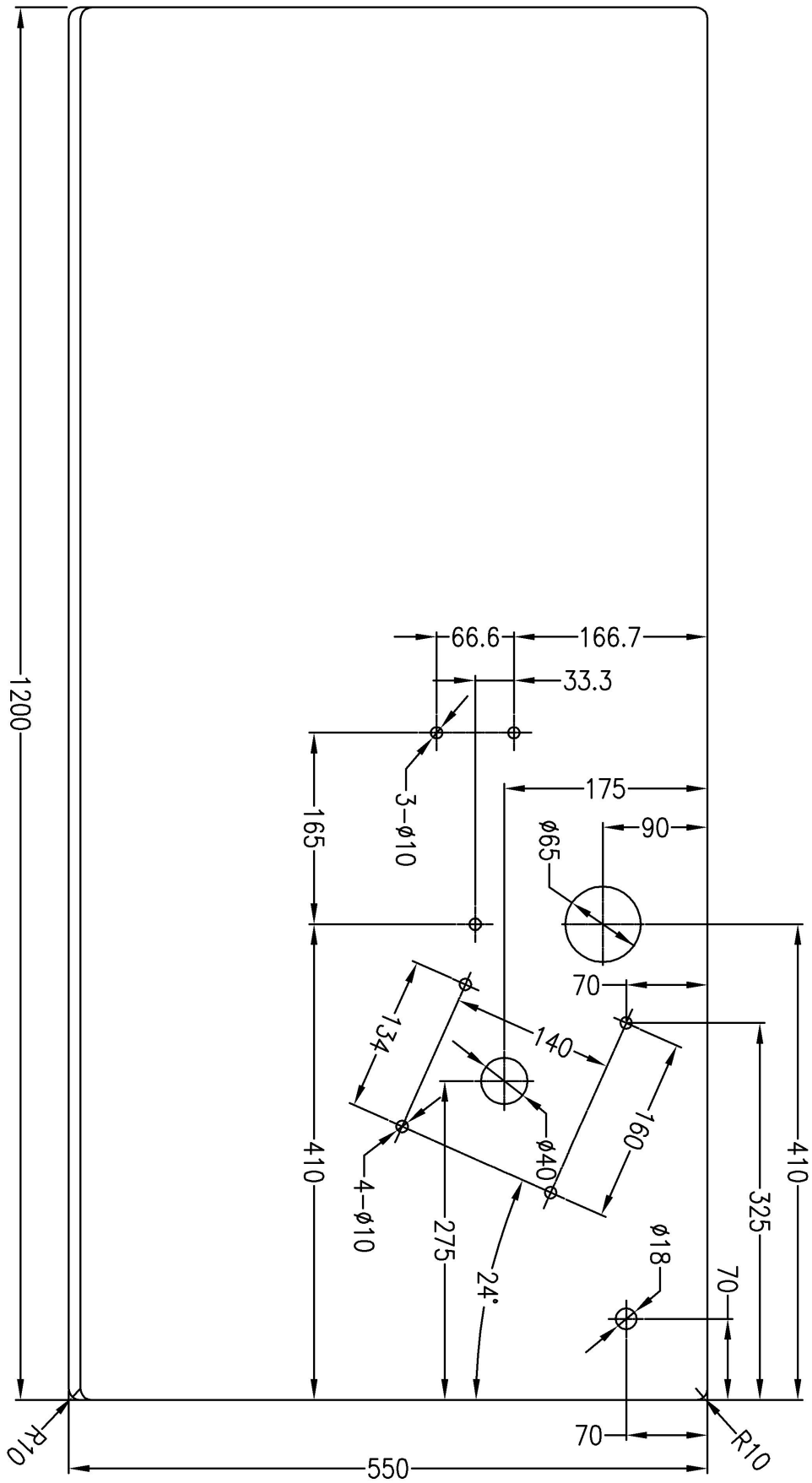

Fig.1

# 1 · Installation 安裝

## 1.2 調整抬壓腳

### 1.2.1 抬壓腳

1. 當壓腳緊貼在針板上時，在抬壓腳連接軸①跟壓腳連接托架②留 1mm 的間隙。(Fig.2,3)

註：壓腳主體跟壓腳彈片之間要有 0.3mm 的間隙。

## 1.2 Adjusting presser foot lift

### 1.2.1 Presser foot lift

1. As standard, make the clearance between the presser bar lifter lever ① and the presser bar connecting bracket ② to 1 mm when the presser foot touches the stitch plate closely.(Fig. 2,3)

Note:

The clearance between the body of the presser foot and presser foot spring plate has 0.3mm.

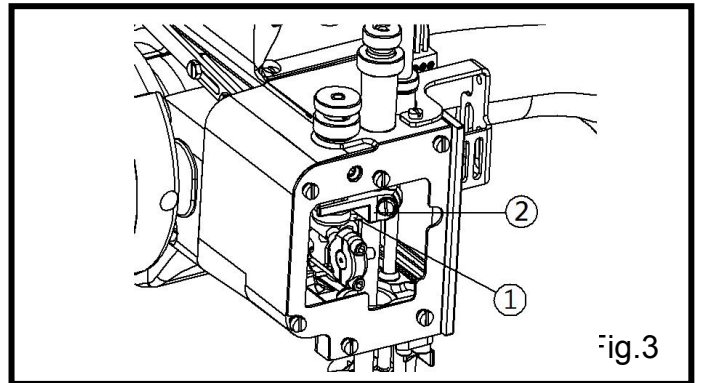
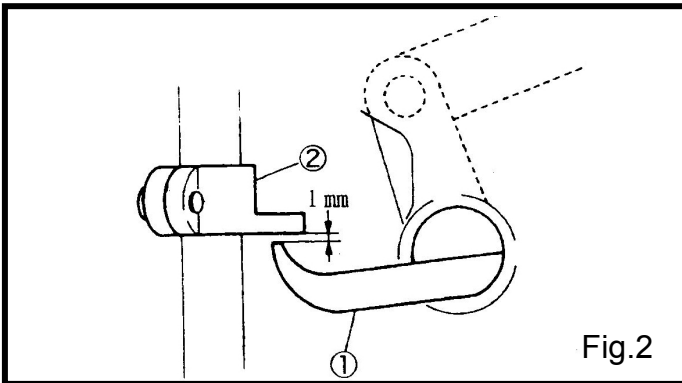

調整：

- (1) 移除油塞③④才可以檢查間隙。(Fig.4)
- (2) 放鬆壓腳連接桿螺絲⑤。(Fig.5)
- (3) 移開壓腳連接桿（短）⑥右邊或左邊去調整間隙。

注意：

在調整抬壓條連接軸①之後，調整抬壓腳在壓腳的最低位置，如果沒有調整，會導致上網線勾損壞。

Adjusting :

- (1) Remove the seal plugs ③④ to check the clearance.(Fig. 4)
- (2) Loosen the screw ⑤ of the presser foot lifter lever link (long). (Fig. 5)
- (3) Move the presser foot lifter lever link (short) ⑥ right or left to adjust the clearance.

**WARNING :**

After adjusting the clearance of the presser bar lifter lever ① , adjust the presser foot lift at the lower point of the presser bar. If not adjusted, it can cause damage to the top cover thread hook.

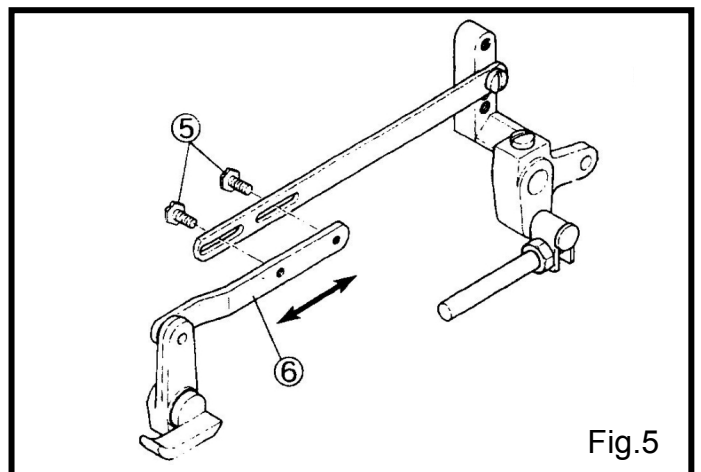
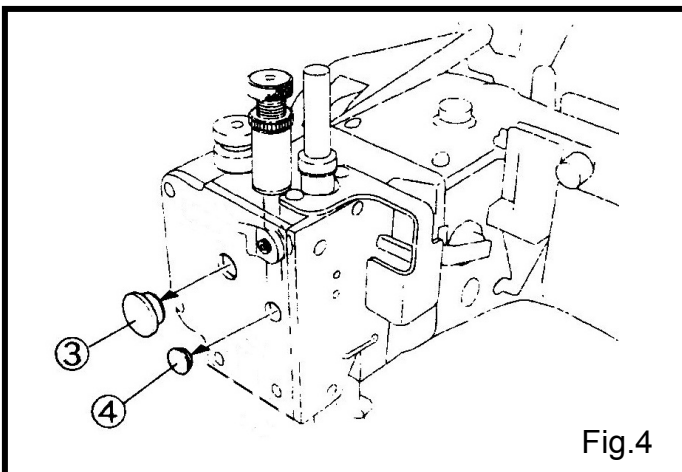

# 1 · Installation 安裝

2. 當針柱在最低位置和壓腳完全抬舉時，針錐①和上網線勾②需留間隙 0.3mm。(Fig.6)

調整：

1. 放鬆螺母③。(Fig.7)
2. 移動抬壓腳停止插銷④或再調整外面間隙。

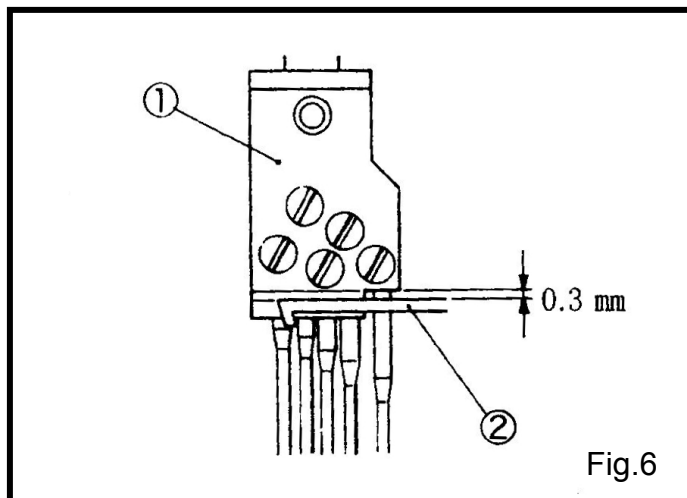

Fig.6

2. As standard, make the clearance between the notch of the needle clamp① and the top cover thread hook② to 0.3mm when the needle bar is at the lowest point and the presser foot is raised by pressing the presser foot pedal. (Fig. 6)

Adjusting :

1. Loosen the lock nut ③ . (Fig.7)
2. Move the presser foot lifter stop plunger ④ in or out to adjust the clearance.

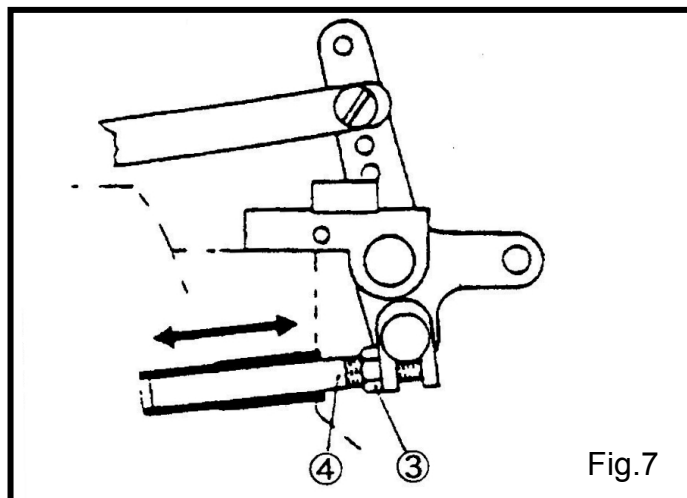

Fig.7

## 1.2.2 過線組

不踩踏板時鬆線器①和鬆線器座之間要有 0.5mm 的間隙。

當踩下踏板時，六個鬆線器①會向上推，之後上夾線片②開始離開下夾線片。(Fig.8)

調整：

- (1) 放開提昇擺臂(大)的螺絲④。(Fig.9)
- (2) 翻轉鬆線器座③用螺絲起子。(Fig.8)

註：

順時針旋轉，減少間隙。

逆時針旋轉，增加間隙。

## 1.2.2 Tension release unit

As standard, make the clearance between the tension release pins ① and the tension release shaft ③ to 0.5mm when six tension release pins ① are pushed up slightly and the upper thread tension disc without pressing the presser foot pedal.(Fig.8)

Adjusting:

- (1) Loosen the screw ④ of the presser bar lifter lever(large).(Fig. 9)
- (2) Turn the tension release shaft ③ with a screwdriver.(Fig. 8)

Note :

- To decrease the clearance, turn it clockwise.
- To increase the clearance, turn it counter clockwise.

# 1 · Installation 安裝

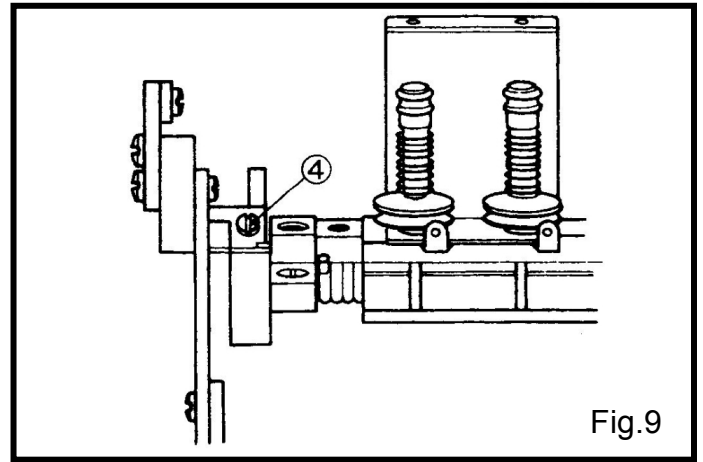
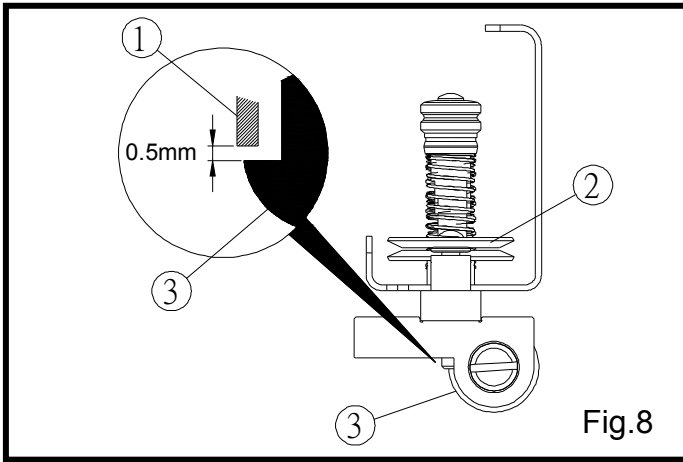

## 1.3 其它部份

### 機頭線架

將線架支柱③裝在線架固定座⑦，再將過線架④用螺絲⑤鎖在線架支柱③，調整過線桿⑥，使穿線平順，不致於線會糾結在一起。(Fig.10)

## 1.3 Other parts

### Setting thread eyelets:

Stand the thread guide plate supports③ on the thread tension support⑦ and fix the thread guide plate④ on the supports③ with the screws⑤.

Adjust the thread pipes⑥ to thread smoothly without entangling. (Fig. 10)

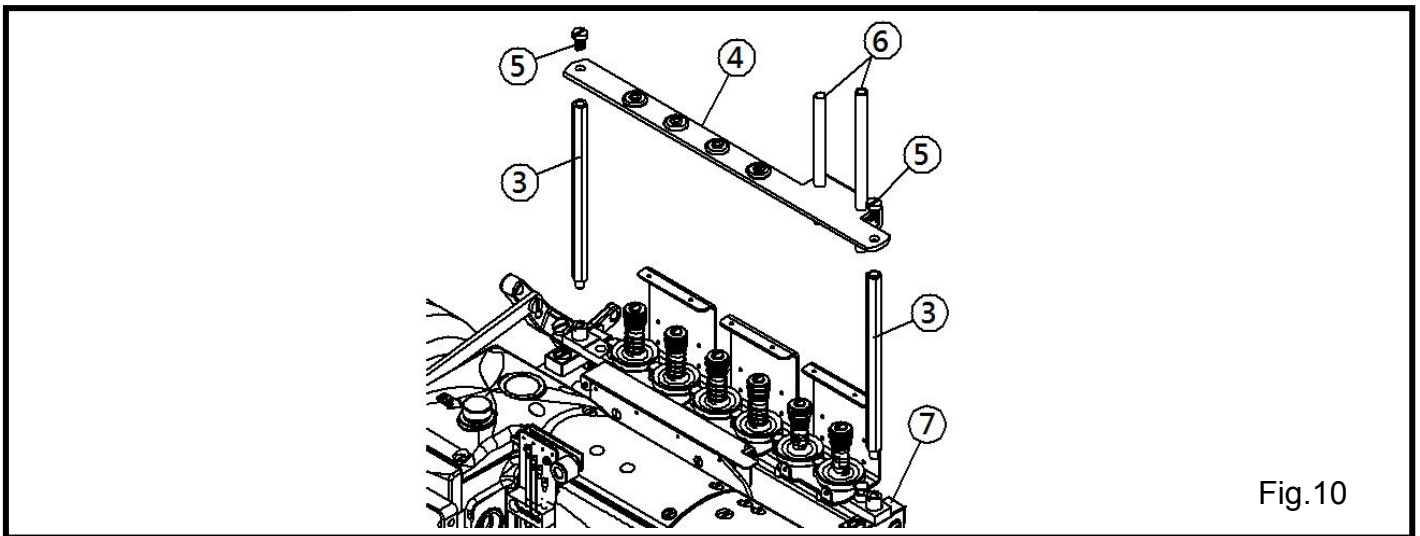

機器轉速最高速為 4200R.P.M，平常使用 2800R.P.M。

在前 200 個小時（約一個月）使用 3000-3360R.P.M 左右的速度，這樣機器使用時間可以延長。

### 注意：

如果運轉方向相反，油無法供應，會造成機器損壞。

The sewing speed is 4200 rpm at the maximum and 2800rpm is usual.

Run a new machine at a speed of 15-20% lower than maximum sewing speed during the first 200 hours(for about one month) so that the machine can offer a long service life in good condition.

### CAUTION :

If rotating in reverse direction, oil can not be supplied properly. It can cause the machine damage.

## 3 · Lubrication 潤滑

### 3.1 潤滑油

注意：

絕對不要在油內加入任何添加物（劑），否則將惡化油的品質，並損害機器。

### 3.2 潤滑系統

- (1) 旋開油塞螺絲 ① 和 ② 然後加油。(Fig.11)
- (2) 從油孔 ① 加油直到油量到 ③ 最上方的紅線，從油孔 ② 加油直到油量到 ④ 最上面的紅線。(Fig.12)
- (3) 使用機器前檢查油水平。如果沒到水平線要加油。
- (4) 當機器在使用中時，從油鏡 ⑤ 和 ⑥ 檢查油有無供應。

注意：

太多或太少的油會造成機器漏油和機器故障。維持油的水平在 2 條紅線之間。

### 3.1 Lubricating oil

CAUTION :

Never add additives to the oil.

If added, it can cause the deterioration of the oil and the machine damage.

### 3.2 Lubricating

- (1) Remove the plug screws ① and ② indicated "OIL" and supply oil.(Fig.11)
- (2) From the plug screw ①, supply oil until the oil level indicator reaches the upper line in the oil sight gauge ③. From the plug screw ②, supply oil to the upper line in the oil sight gauge ④.(Fig.12)
- (3) Check the oil level between the lines in the oil sight gauge ③ and ④ before running a machine. If it is under the lines, supply oil.
- (4) Check the oil splashes from the nozzle inside the oil sight top windows ⑤ and ⑥ when starting to run a machine.

CAUTION :

Too much oil or not enough oil can cause oil leakage and machine trouble. Be sure to keep the oil level between the lines.

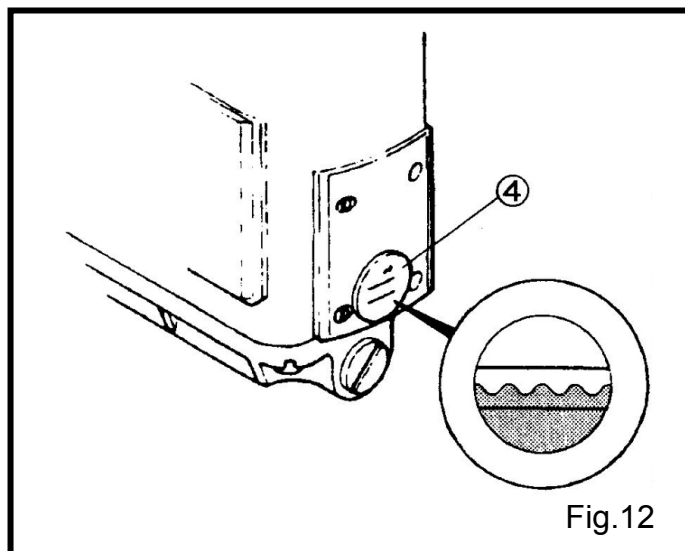
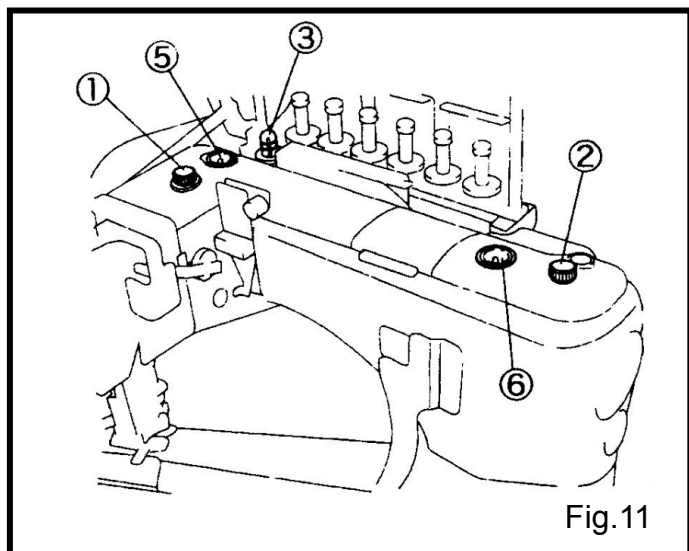

## 3 · Lubrication 潤滑

### 3.3 啟動注油

裝新機器或使用久未使用的機器，如果油沒有循環完整，需移除幫浦上的油塞螺絲①，注入油後裝回螺絲再使用機器。(Fig.13)

### 3.3 Priming oil

Prime oil if oil does not circulate completely when installing a new machine or running a machine which has not been used for a while.

Remove the plug screws① of the pump driven gear to prime oil. Run a machine after resetting them①. (Fig.13)

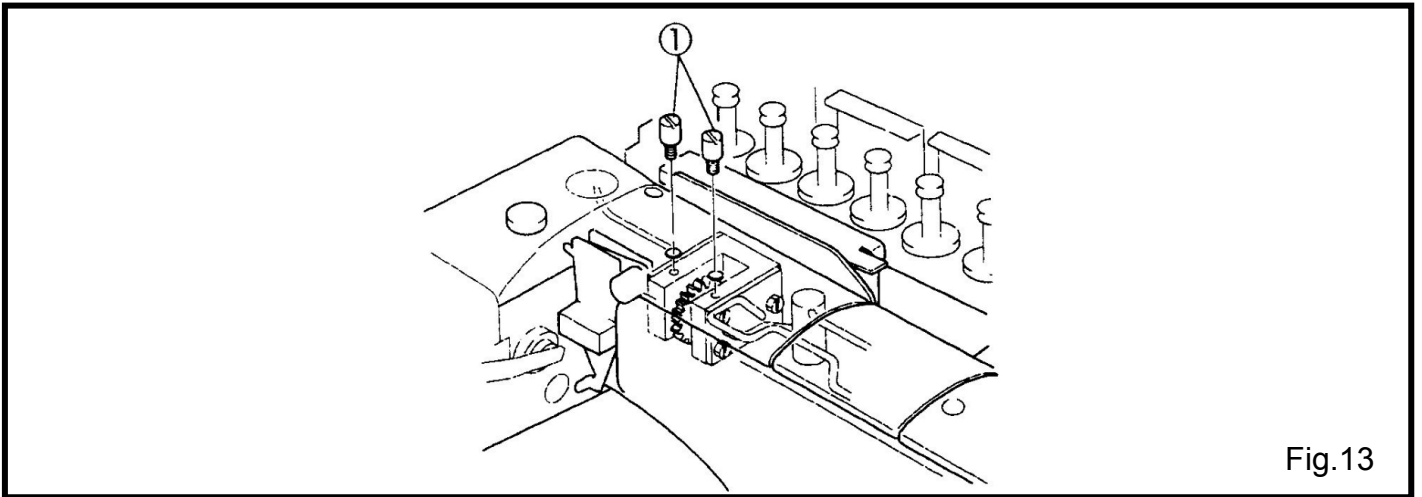

Fig.13

### 3.4 補充油

在箭頭處需滴一些油潤滑。如果油漏在壓腳和上刀周圍會導致沾汙布，要確實的把油擦乾淨。(Fig.14,15,16)

### 3.4 Replenishing oil

Replenish a drop of oil from the points indicated arrows with an oiler (accessories) if needed.

If oil leaks around the presser foot and the upper knife, it can cause oil stain on the material. Be sure to wipe it completely. (Fig.14,15,16)

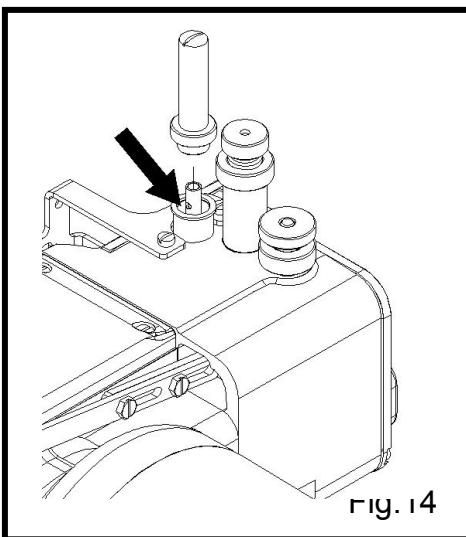

Fig.14

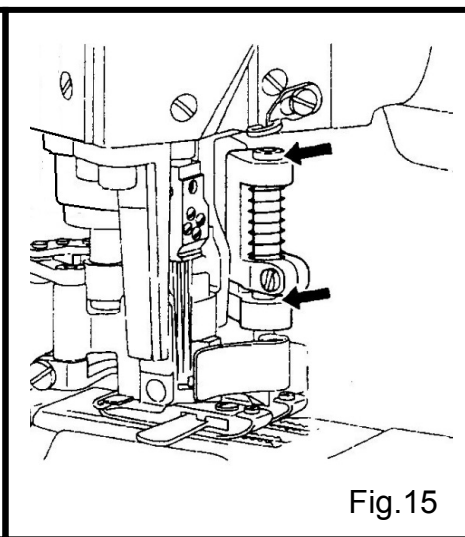

Fig.15

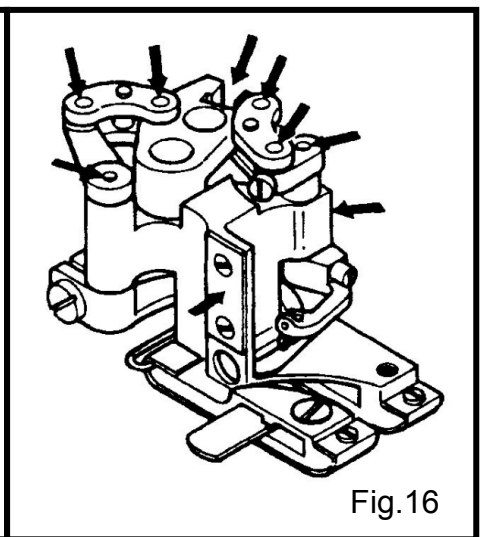

Fig.16



## 3 · Lubrication 潤滑

### 3.5 更換油

#### 3.5.1 換油時機

新機使用 200 小時（約使用一個月）後，要更換新油，之後每年換新油 1-2 次。

#### 3.5.2 換油程序

- (1) 分別在螺絲 ① 和 ② 下面放置接油容器。  
(Fig.17,18)
- (2) 拆下螺絲 ① 和 ② 後油會自行流出。
- (3) 裝回螺絲 ① 和 ② 。
- (4) 注入新油。

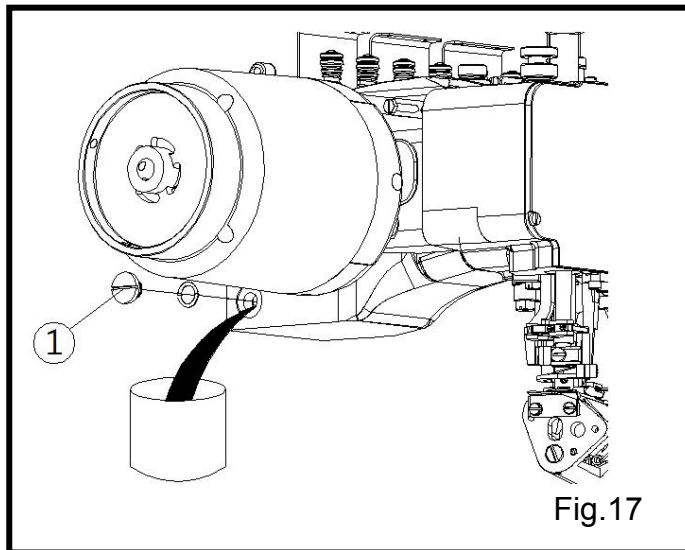

### 3.5 Changing oil

#### 3.5.1 Period of changing :

When using a new machine, change the lubricating oil after running for 200 hours (for about one month). After that, change the oil once or twice a year.

#### Procedure for changing :

- (1) Set containers received the oil under the screws ① and ② respectively.(Fig.17,18)
- (2) After removing screws ① and ② ,the oil is drained.
- (3) Reset the screws ① and ② .
- (4) Fill the new oil.

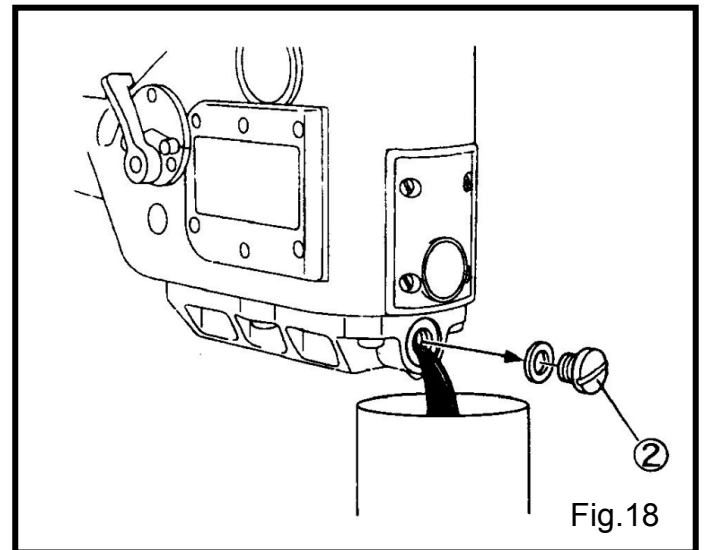

## 4 · Proper operation 使用說明

### 4.1 車針系列

#### 4.1.1 縫紉機用針

格洛茲貝克牌：UY118GKS

風琴牌：FLX118GCS

提醒：

請選用適合的針給不同的材料。有些尺寸並沒有販售，請從目錄上確認尺寸。

### 4.1 Needle system

#### 4.1.1 Sewing needle :

Groz-Beckert : UY118GKS

Organ : FLX118GCS

Note:

Select the proper sewing needle in size depending on thickness and type of material.

Japanese standard 日本規格	8	9	10	11	12	14
Metric Standard 公制規格	60	65	70	75	80	90

表格一

#### 4.1.2 假針

四支針配合一支假針。

格洛茲貝克牌：36211, 36211A

風琴牌：FLG-1, FLG-8

提醒：

請選用適合的假針去使用不同的材料。有些尺寸並沒有販售，請從目錄上確認尺寸。

#### 4.1.2 Retainer needle :

One retainer needle is used with four sewing needles.

Groz-Beckert : 36211, 36211A

Organ : FLG-1, FLG-8

Note:

Select the proper sewing needle in size depending on thickness and type of material.

Japanese standard 日本規格	8	9	10	11	12
Metric Standard 公制規格	60	65	70	75	80

表格二

## 4 · Proper operation 使用說明

### 4.2 針的安裝

- (1) 旋轉轉輪將針抬到最高點。
- (2) 放鬆螺絲 ①。(Fig.19)
- (3) 平面擺在前方將新針放入針鑷內最頂端，然後鎖緊螺絲 ①。

注意：

安裝針之前一定要先把馬達關掉，並確定馬達不會轉動。

### 4.2 Installing needle

- (1) Rotate the handwheel to raise the needles at the highest point.
- (2) Loosen the screws ① and pull the needles down.(Fig.19)
- (3) Face the flat parts front, insert new needles into the needle clamp as far as they will go. Tighten them with the screws ① securely.

**WARNING :**

Before installing the needles, always turn the motor switch OFF and check that the motor has already stopped.

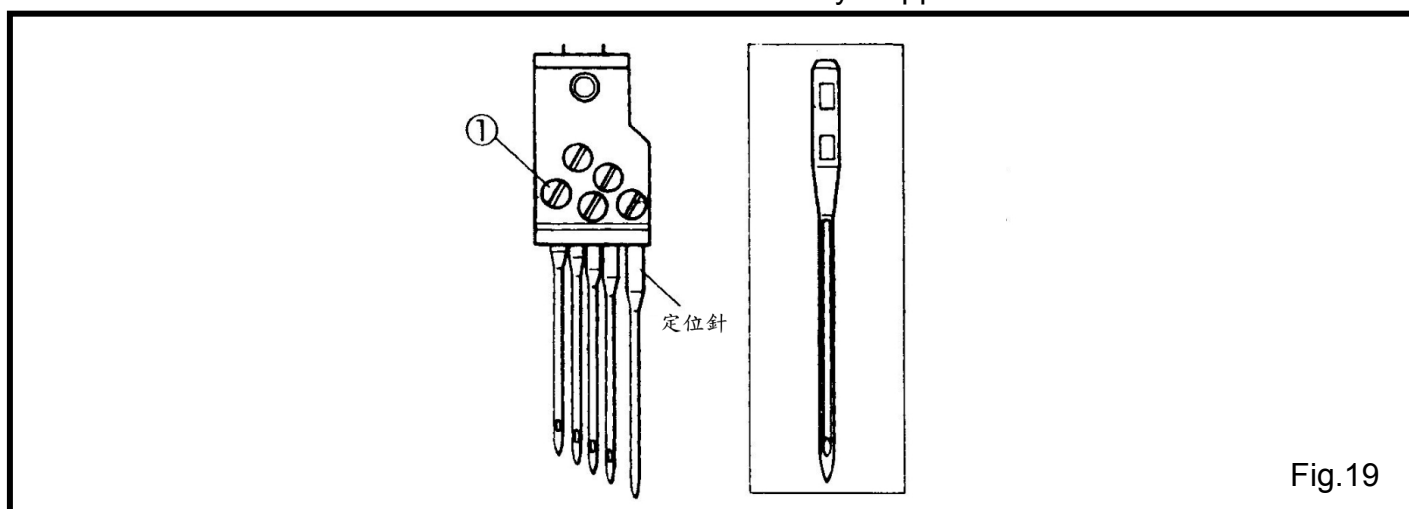

### 4.3 線

先用易穿的線從 ABCDEF 孔穿至針鑷前，然後結上要用的線拉到針前，把結剪掉。

線正確位置(Fig.20)。

A, B, C, D : 針線

E : 上飾線

F : 下勾針線

提醒：

當抬起壓腳時，線架組會平穩的放開，此時可輕鬆的將線拉過。

穿下鉤針線時不須把針板拆掉。

注意：

穿線前一定要先把電源關掉，並確定馬達完全停止。

### 4.3 Threading

When threaded, pull the thread out until it is in front of the needles. Then cut off the knot before needle eye to rethread. When threaded, pull the thread out until the knot is out. Then cut off the knot.(Fig.20)

A, B, C, D : Needle thread

E : Top cover thread

F : Lower looper thread

Note:

When raising presser foot, thread tension will be released to take up smoothly.

Improper threading can cause thread breakage, skip stitch, and uneven stitch.

**WARNING :**

Before threading, always turn the motor switch OFF and check that the motor has already stopped.

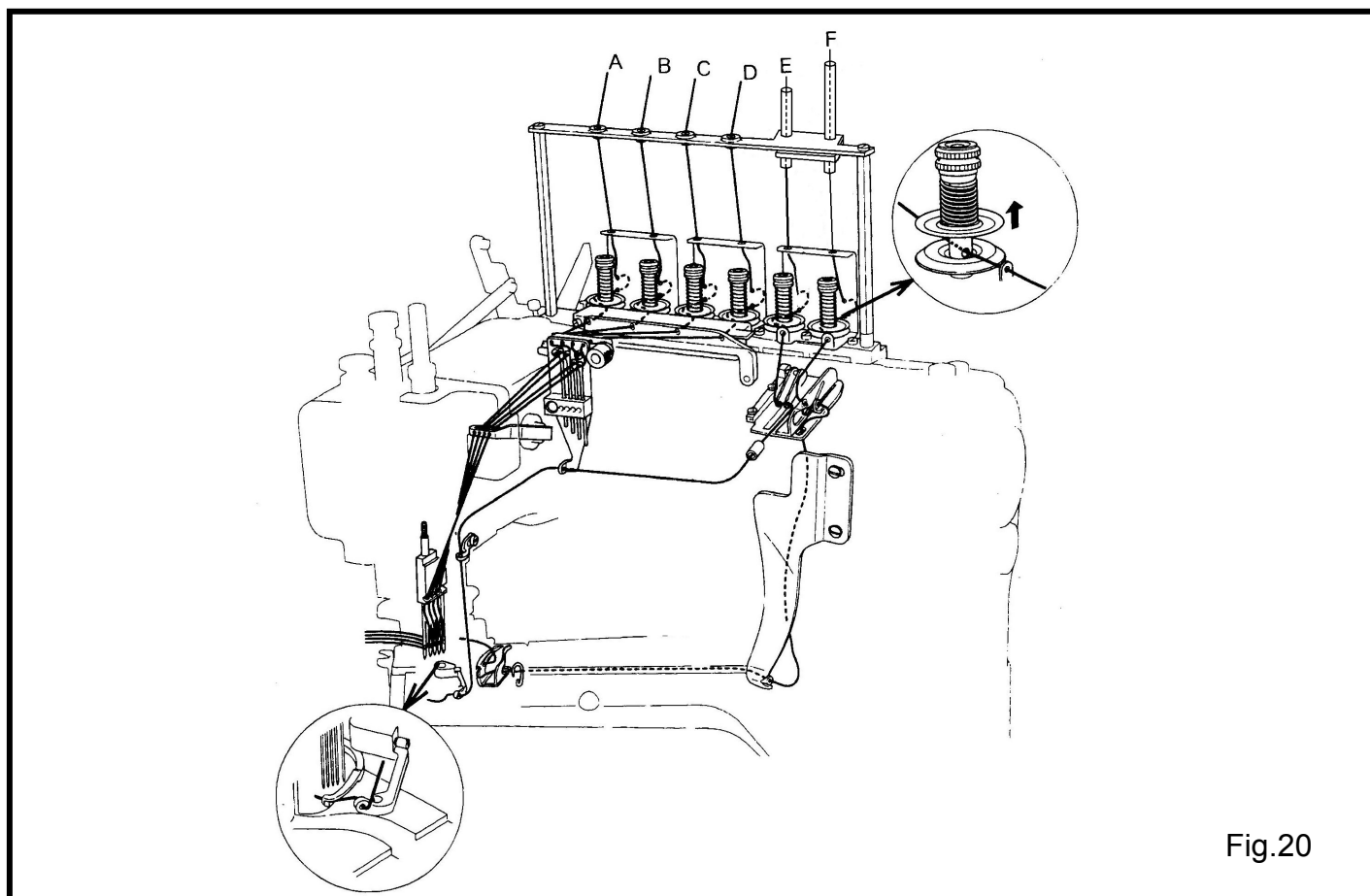

Fig.20

#### 4.4 線鬆緊

調整線架上的鬆緊度是靠螺母①-⑥取決於布線寬度和其它狀況。(Fig.21)

①-④：針的線（①：右針，④：左針）

⑤：上網線

⑥：下網線

- 如果調緊線時，以順時間方向調下①-⑥螺絲。
- 如果調鬆線時，以逆時間方向調上①-⑥螺絲。

#### 4.4 Thread tension

Adjust the thread tension with the tension adjusting nuts ①-⑥ depending on fabric type, thread type, seam width, stitch length, and other sewing conditions.(Fig.21)

①-④：needle threads (①：right needle, ④：left needle)

⑤：top cover thread

⑥：looper thread

- To tighten the thread tension, turn the nuts clockwise.
- To loosen the thread tension, turn nuts counter-clockwise.

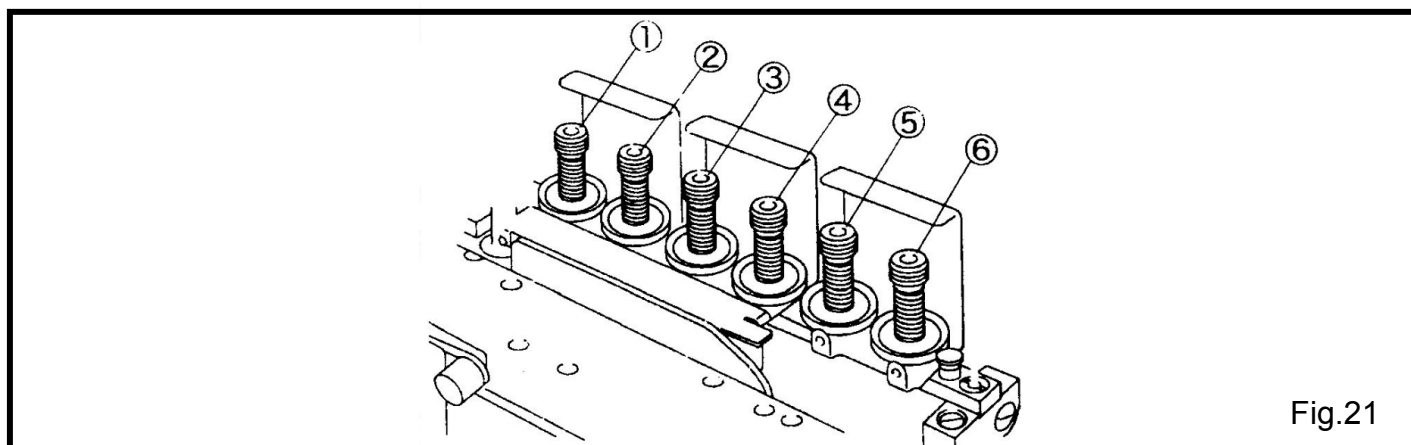

Fig.21

## 4 · Proper operation 使用說明

### 4.5 調整壓腳壓力

放鬆螺母⑦然後用壓腳柱螺帽⑧來調壓力。(Fig.22)

- 增加壓腳壓力時，順時間調整螺帽⑧。
- 減少壓腳壓力時，逆時間調整螺帽⑧。

提醒：

儘可能保持壓腳壓力在最鬆的狀態，使布在針板上更加平穩。

### 4.5 Pressure of presser foot

Loosen the lock nut⑦ and turn the adjusting screw⑧ to adjust the pressure.(Fig.22)

- To increase the pressure, turn the adjusting screw⑧ clockwise.
- To decrease the pressure, turn the adjusting screw⑧ counterclockwise.

Note:

Keep the pressure as low as possible for stable stitches.

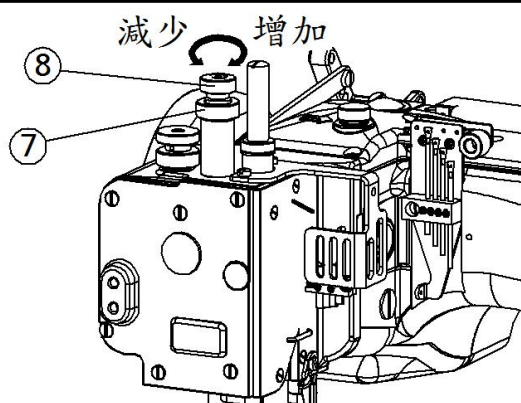

Fig.22

### 4.6 調整壓腳高低

輕微的調高或降低壓腳都會有明顯的成效。

- 預防勾齒抓痕。
- 改善壓腳彈片的耐久度。
- 增減壓腳彈片的壓力度。
- 減少噪音和振動。
- 可細微的調整針織的寬度。

(1) 針在最底點的位置。

(2) 鬆開螺絲①，然後逆時間旋轉調整螺母②抬起壓腳。(Fig.23)

(3) 在壓腳④和壓腳彈片③之間調出0.3-0.5mm的間隙。(Fig.24)

(4) 把螺母①鎖回去。

### 4.6 Up-and-down position of presser foot

Following effective points will be obtained by slightly raising the presser foot.

- Prevention of fabric jam
- Prevention of feed scratch mark
- Improvement of durability of presser foot spring plate
- Reduction of vibration and noise
- Available for fine adjustment of lapped fabric width.

(1) Position the needle at the lowest point.

(2) Loosen the lock nut① and run the adjusting nut② counterclockwise to raise the presser foot.(Fig.23)

(3) Adjust the clearance between the bottom④ of the presser foot and the presser foot spring plate③ to 0.3-0.5 mm.(Fig.24)

(4) Tighten the lock nut① securely.

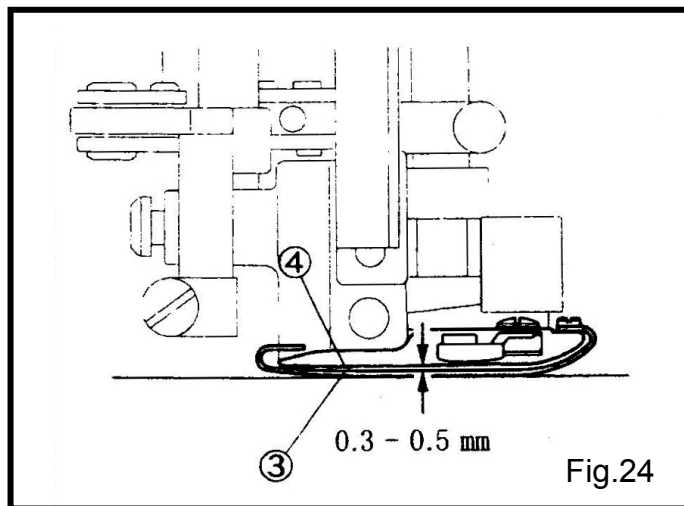
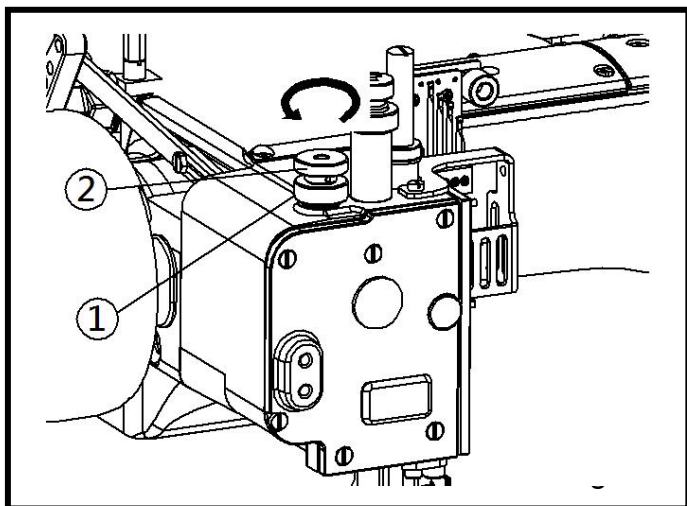

#### 4.7 調整差動

- (1) 移動調整桿向右或左去調整差動桿 ⑤ 在刻度“4”和刻度“5”之間是相同的動作和差動。即主牙和差動牙的運作相同。(Fig.25)
- (2) 螺絲 ⑥ 是用來固定調整桿 ⑤ 和保持差動的多或少。

  - 一般差動比：調整桿 ⑤ 調到刻度“9”的位置。
  - 反差動比：調整桿 ⑤ 調到刻度“1”的位置。

#### 注意：

在調整機器之前，一定要先把電源關掉，並確定馬達完全停止。

#### 4.7 Adjusting differential feed dog

- (1) Move the differential feed operating lever ⑤ right or left to adjust differential feed dog. The lever ⑤ between the graduations “4” and “5” makes the equal movement of the main and the differential feed dogs. (Fig.25)
- (2) The screw ⑥ is for fixing the lever ⑤ and keeping the differential movement adjusted.

  - To make normal differential, move the lever ⑤ to “9”.
  - To make reverse differential, move the lever ⑤ to “1”

#### WARNING :

Before adjusting, always turn the motor switch OFF and check that the motor has already

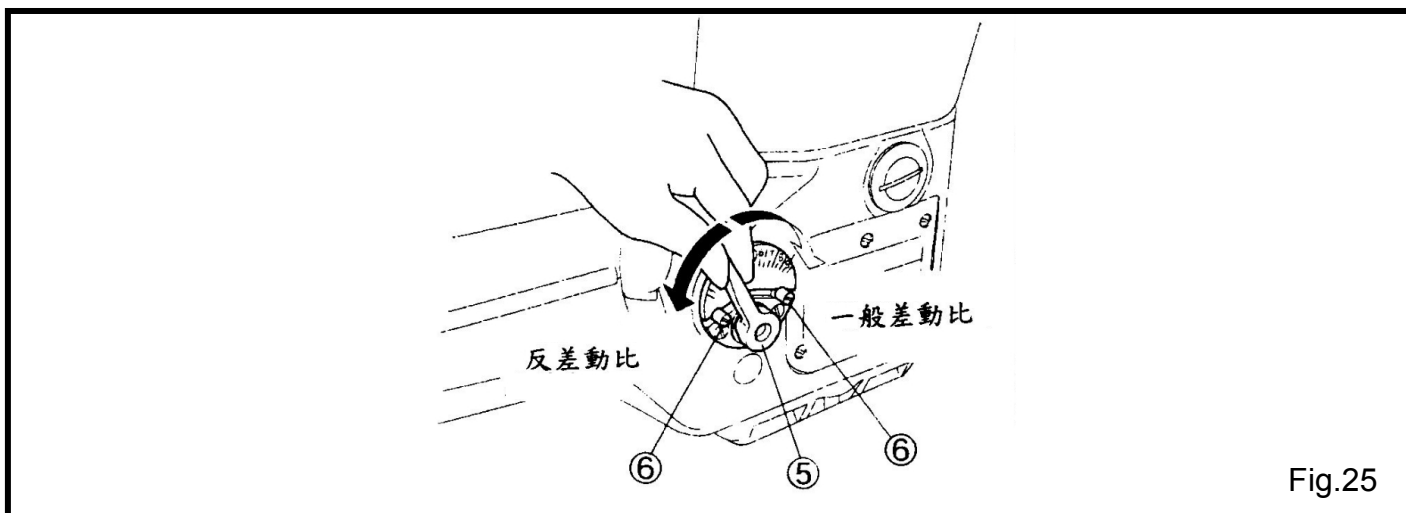

## 4 · Proper operation 使用說明

### 4.8 調整針距

粗細針的範圍標準為 1.6-2.5mm，但可調整至更大。

調整：

- (1) 放鬆螺絲①，移動針檔②（後）到最後面。然後輕微鎖緊。減少針寬時可以省略。(Fig.26)
- (2) 退掉油塞螺絲③。(Fig.27)
- (3) 放鬆螺絲④去調整粗細針。
- (4) 鎖緊螺絲④和重新裝上油塞螺絲①。

- 增加針距時，將螺絲④向上調整。
- 減少針距時，將螺絲④向下調整。

注意：

油塞螺絲③要鎖緊防止漏油。

### 4.8 Adjusting stitch length

Stitch length ranges 1.6-2.5 mm as standard and can be adjustable infinitely.

Adjusting :

- (1) Loosen the screw① and move the needle guard (rear) ② most rearward. Then tighten it slightly. This is skipped when decreased the stitch length.(Fig.26)
- (2) Remove the plug screw③.(Fig.27)
- (3) Loosen the screw④ to adjust the stitch length.
- (4) Tighten the screw④ securely and reset the plug screw①.

- To increase stitch length, move the screw④ upward.
- To decrease stitch length, move the screw④ downward.

CAUTION :

Tighten the plug screw③ securely to prevent oil leakage.

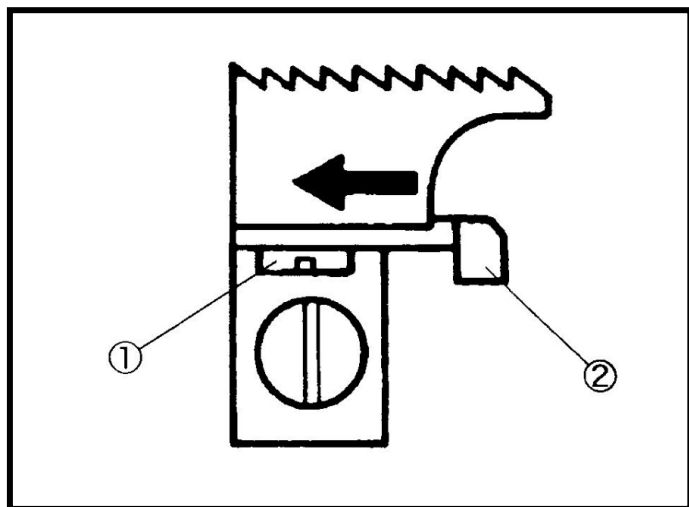

表格三為針距大小使每英吋或每 30mm 的距離有幾針。

注意：

調整針距必須注意後針檔的位置。

提醒：

每次在更換不同的狗齒之後，都要調整粗細針。

注意：

在調整機器前，一定要先把電源關掉，並確定馬達完全停止。

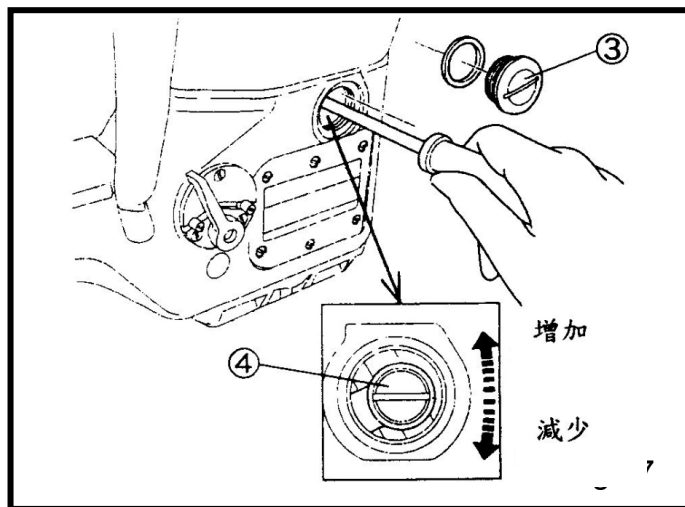

Table 3 shows the number of stitches per inch(25.4 mm) and 30 mm converted stitch length.

CAUTION :

Be sure to adjust needle guard(rear) after changing stitch length to prevent breakage of the parts.

Advice adjustment :

Always adjust stitch length after changing differential feed dog.

WARNING :

Before adjusting, always turn the motor switch OFF and check that the motor has already stopped.

針距(mm)	1 英寸針數	30mm 針數
2.5	10	12
2.1	12	14
1.8	14	16.5
1.6	16	19
1.2	21	25
1	25	30

表格三

## 4.9 調整切布刀

- (1) 底刀①的標準位置要留距離在底刀①尖端和鎖底刀座②之間 0-0.5mm。(Fig.28)
- (2) 當上刀③在最左邊時，上刀③和底刀①要有 0.5mm 的重疊。(Fig.29)
- (3) 放鬆螺絲④和⑤去調整上刀和底刀。(Fig.28, 30)

## 4.9 Adjusting lapped width of upper fabric

- (1) For the standard position of the lower knife①, make the distance between the lower knife① tip and the lower knife clamp② to 0-0.5 mm. (Fig. 28)
- (2) For the standard position of the upper knife③, engage between the upper knife③ and lower knife① to 0.5 mm when the upper knife③ is at the extreme left.(Fig.29)
- (3) Loosen the screws④ and⑤ to adjust the lower and upper knives respectively.( Fig.28 , 30)

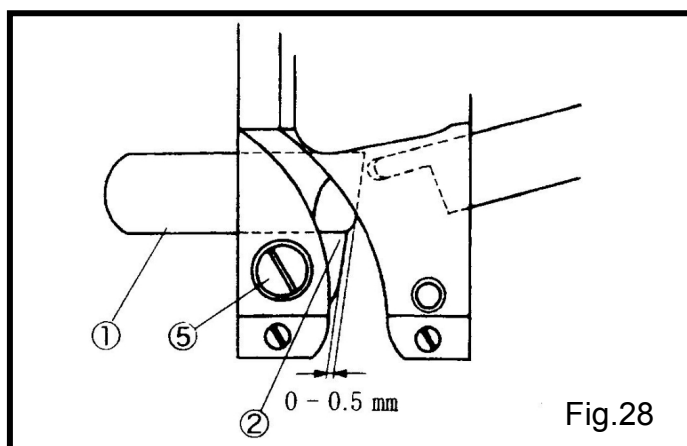

Fig.28

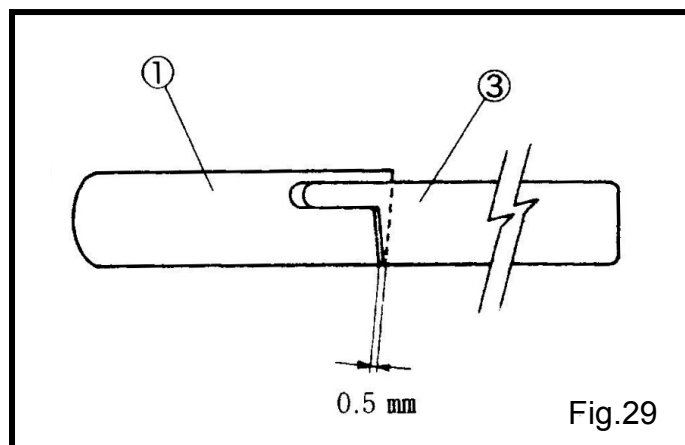

Fig.29

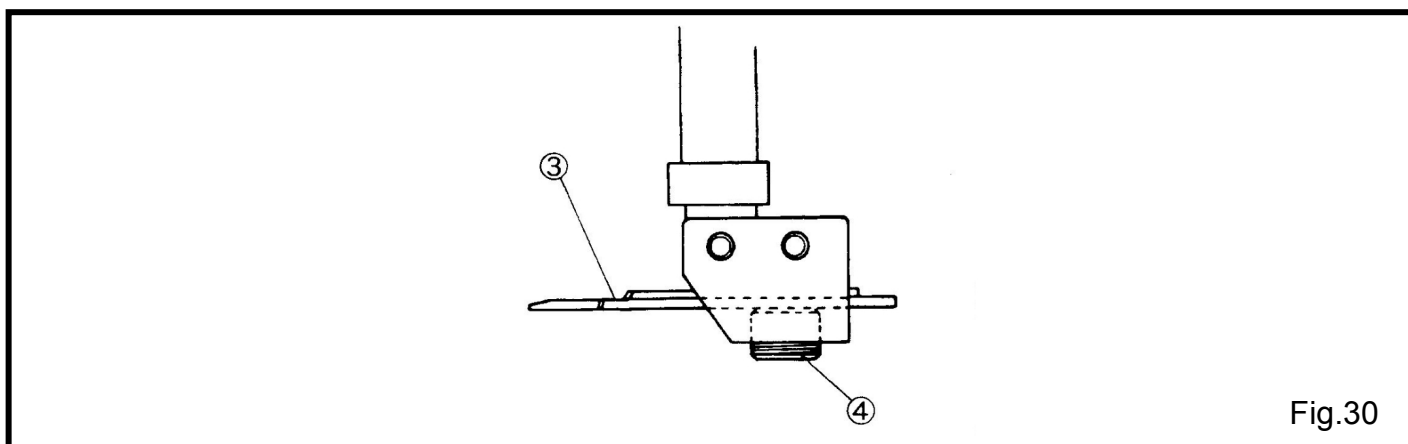

Fig.30



## 4 · Proper operation 使用說明

### 4.10 過線油組

當機器在高速運轉或使用特殊線或特殊纖維時，  
矽油壺組是標準配備，以防止斷線跳針。

當使用機器時，將毛氈①放入矽油壺②內。

(Fig.31)

注意：

1. 當不使用矽油壺組時，要取出毛氈①。不然可能在車縫時發生不正常情況。
2. 當矽油沾到其他零件時，可能引起機器損傷，故要將油擦乾淨。

使用乙烷樹脂

打開油壺蓋③，檢查油量。如果不夠，添加油於油壺②。

### 4.10 SP device

SP device (needle thread oiling) is equipped as standard to prevent thread breakage and skip stitch when running a machine at high speed or using synthetic thread and/or synthetic fabric.

Fix the felts① included accessories into the SP tank② when using.(Fig.31)

CAUTION :

1. When not using SP device, remove the felts①. If not, it may occur irregular condition during sewing.
2. If the silicone oil stuck to the parts other than SP device, it can cause the machine damage. Be sure to wipe it away.

Use dimethyl silicone oil

Open the oil cup lid③ and check the oil amount. If not enough, supply oil into the SP tank②.

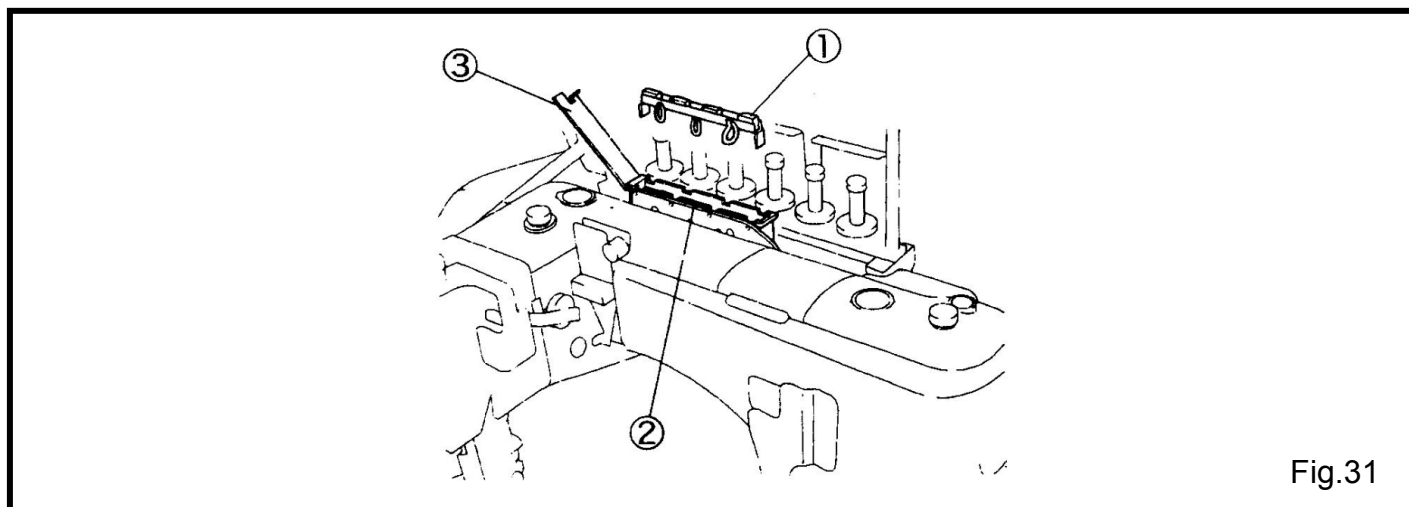

Fig.31

## 4 · Proper operation 使用說明

### 4.11 導布器

#### 4.11.1 調整左右邊的標準位置

鬆開螺絲④調整位置，視刀的邊緣和刀齒去輕微的調整使導布器上的A點跟4支針的中間成一直線。(Fig.32,33)

#### 4.11.2 調整前後的標準位置

設定滑塊②的停止位置在針板③前。視刀厚去輕微的調整位置

#### 注意：

在調整機器之前，一定要先把電源關掉，並確定馬達完全停止。

### 4.11 Use of lap former

#### 4.11.1 Standard left-and-right position

Align the point A of the lap former① with the center of four needles. Depending on lapped edges of the fabrics or fabric feeding, loosen the screws④ and adjust the position. (Fig.32,33)

#### 4.11.2 Standard front-and-rear position

Set the position where the lap former slide block② touches and stops in the front of the stitch plate③. Depending on fabric thickness, adjust the position slightly toward the operator.

#### WARNING :

Before adjusting, always turn the motor switch OFF and check that the motor has already stopped.

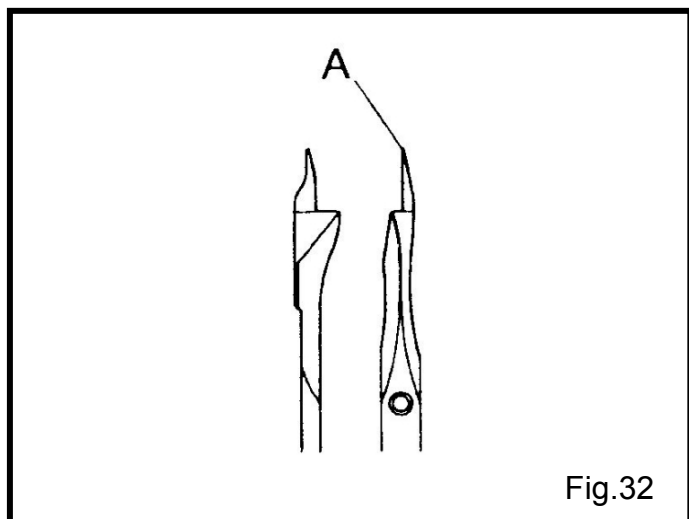

Fig.32

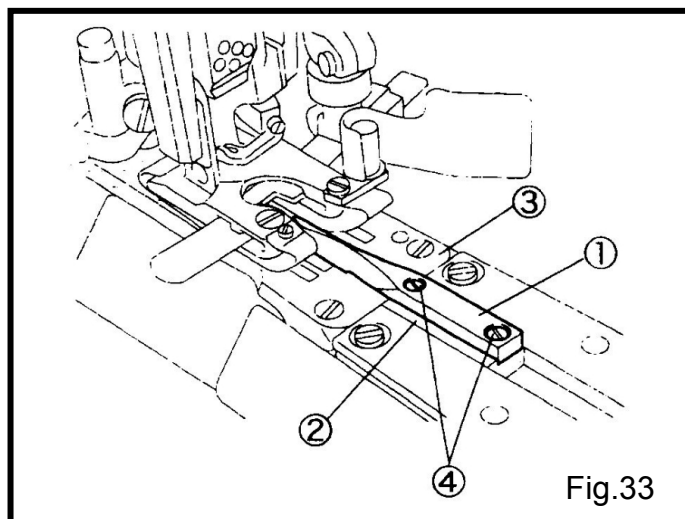

Fig.33

## 5 · Adjustments 調節裝置

### 5.1 針線鬆緊

#### 5.1.1 針線線圈調整片

4 支針各有自己的過線片可調整線圈的鬆緊。

- (1) 抬線架①轉到最低位置。(Fig.34)
- (2) 第一片②要跟右邊第四針的線平齊。(Fig.35)
- (3) 設定第四片③離第一片②的高度為 3.2mm。
- (4) 設定第三片④離第一片②的高度為 1.6mm。
- (5) 設定第二片⑤離第一片②的高度為 0.8mm。
- (6) 對準後鎖緊螺絲⑥。

註：檢查最上面那片的水平。

- 要把線圈變大就把過線片往上移“L”。
- 要把線圈變小就把過線片往下移“S”。

注意：

在調整機器之前，一定要先把電源關掉，並確定馬達完全停止。

### 5.1 Needle thread tension

#### 5.1.1 Needle thread strike-off pin

Each of four needles has the needle thread strike-off pin which adjusts the thread tension respectively.

- (1) Position the needle thread take-up① at the lowest point. (Fig.34)
- (2) Set the top of pin② even with the needle thread as the fourth right needle. (Fig.35)
- (3) Set the pin③ 3.2 mm higher than the pin②.
- (4) Set the pin④ 1.6 mm higher than the pin②.
- (5) Set the pin⑤ even with or 0.8 mm higher than the pin②.
- (6) Tighten the screws⑥ securely.

Note: Check the tops of the pins are horizontally.

- To make the loop larger, move the pins in the direction “L”.
- To make the loop smaller, move the pins in the direction “S”.

### WARNING

Before adjusting, always turn the motor switch OFF and check that the motor has already stopped.

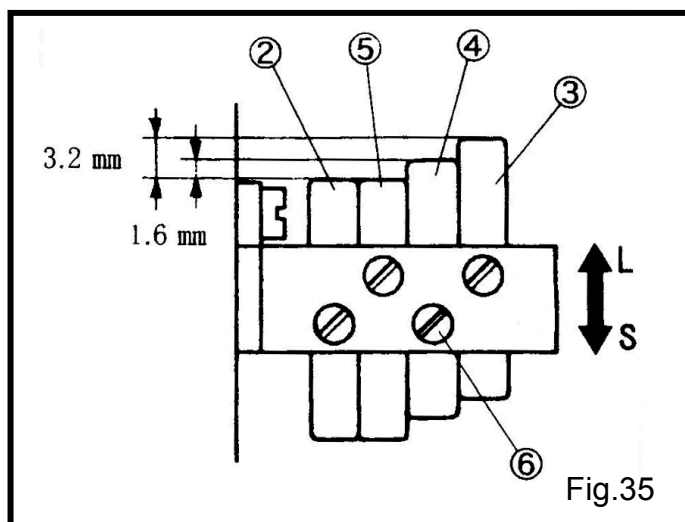
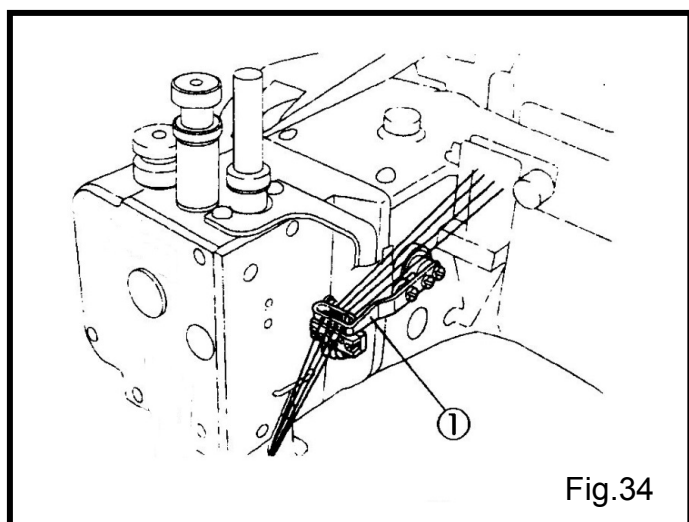

## 5 · Adjustments 調節裝置

### 5.1.2 針線孔

(1) 右邊最高的過線孔①要跟線孔③成一直線。(Fig.36,37)

(2) 設定過線孔④比①低 5mm。

(3) 設定過線孔⑤比①低 9mm。

(4) 設定過線孔⑥比①低 15mm。

- 過線片往下移，線就會變緊。
- 過線片往上移，線就會變鬆。

#### 注意：

在調整機器之前，一定要先把電源關掉，並確定馬達完全停止。

### 5.1.2 Needle thread eyelet

(1) Make the height of the right needle thread eyelets① to align their eyes with the eyes③ of the needle thread eyelet holder.(Fig.36,37)

(2) Set the eyelet④ 5 mm lower than the eyelet①.

(3) Set the eyelet⑤ 9 mm lower than the eyelet①.

(4) Set the eyelet⑥ 15 mm lower than the eyelet①.

- To tighten needle thread, move the eyelets in the direction "T".
- To loosen needle thread, move the eyelets in the direction "L".

#### WARNING :

Before adjusting, always turn the motor switch OFF and check that the motor has already stopped.

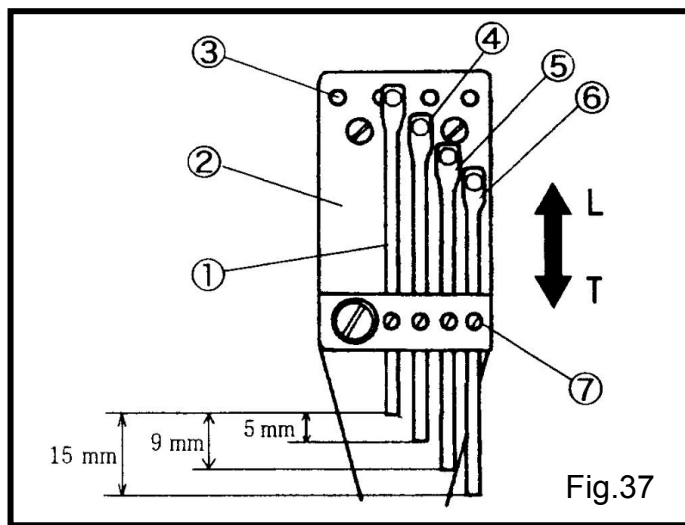
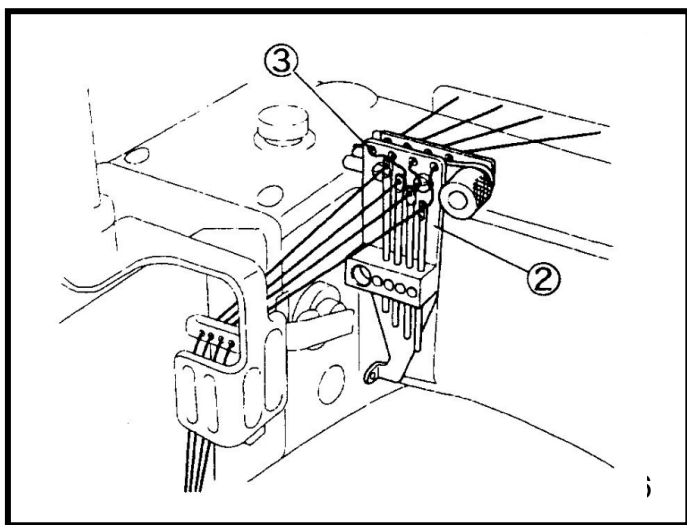

### 5.2 下底線

底線導板①和支撐②要成一直線。(Fig.38)

#### 5.2.1 底線收緊時機

正確的凸輪④位置是當針桿③最高的位置下移 2.8mm 時，線通過 A 點。放鬆⑤去調整。

(Fig.38,39)

### 5.2 Looper thread tension

Align the right of the looper thread take-up guide① with that of the eyelet supporting plate②.(Fig.38)

#### 5.2.1 Timing of looper thread take-up

Position the looper thread take-up④ as standard so that looper thread passes at the point A when the needle bar③ is lowered 2.8 mm from the highest point. Loosen the screws⑤ to adjust it.(Fig.38,39)

## 5 · Adjustments 調節裝置

- 增加底線的鬆度，把線凸調快。
- 減少底線的鬆度，把線凸調慢。

註：當調整凸輪④時，面向凸輪④凸出的地方和上線抬起時不用調整前後位置。

注意：

如果時間差調超過會造成跳針。

- To increase the looper thread take-up amount, hasten the timing.
- To decrease the looper thread take-up amount, delay the timing.

Note :

When adjusting take-up④, face both bosses of the take-up④ and the top cover thread take-up without shifting the front-and-rear position.

**CAUTION :**

If the timing of the looper thread take-up exceeds the adjustable range, it may occur skip stitch.

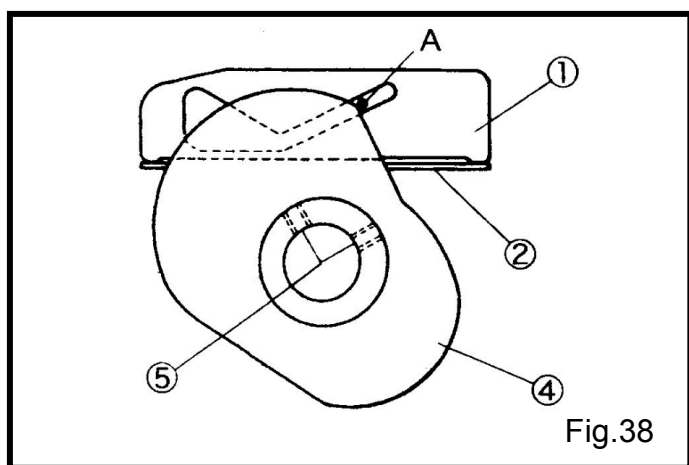

Fig.38

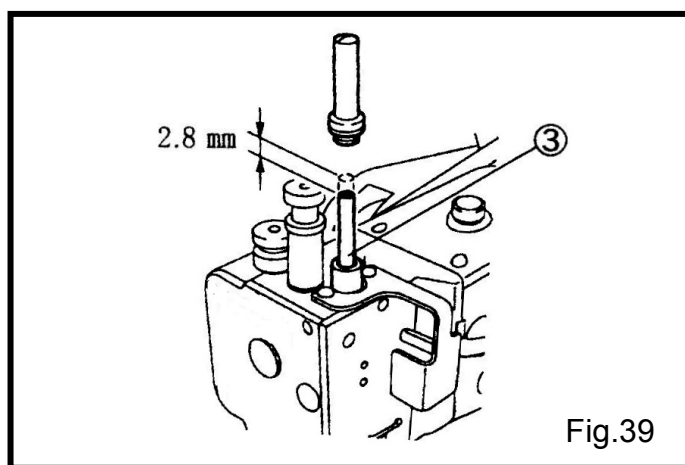

Fig.39

### 5.2.2 下勾針凸輪的位置

底線過線片⑥和⑦標準位置為最右邊。放鬆螺絲⑧和⑨左右移動去調整。(Fig.40)

- 增加底線的量，將過線片往“L”的方向移動。
- 減少底線的量，將過線片往“S”的方向移動。

注意：

在調整機器之前，一定要先把電源關掉，並確定馬達完全停止。

### 5.2.2 Position of looper thread take-up eyelet

Set the looper thread take-up eyelets⑥ and ⑦ at the extreme right as standard. Loosen the screws⑧ and ⑨, and move them right or left to adjust ti.(Fig.40)

- To increase the looper thread take-up amount, move them in the direction “L”.
- To decrease the looper thread take-up amount, move them in the direction “S”.

**WARNING**

Before adjusting, always turn the motor switch OFF and check that the motor has already stopped.

## 5 · Adjustments 調節裝置

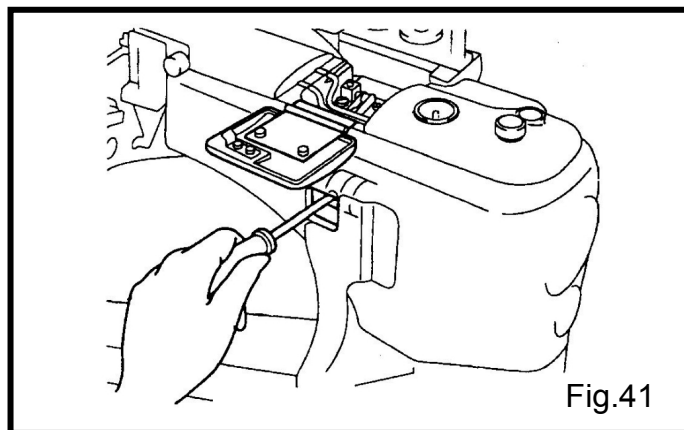
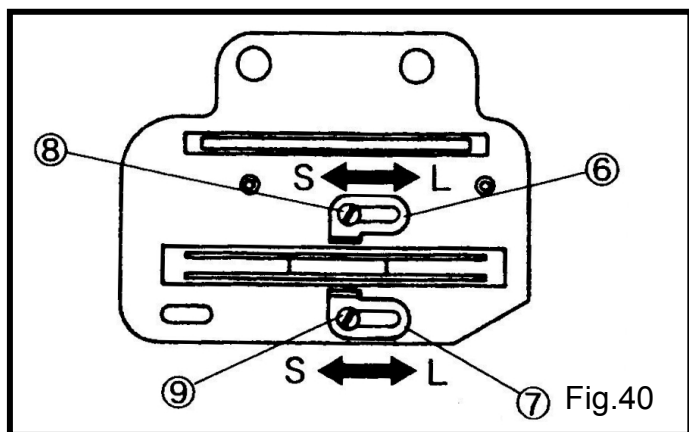

### 5.3 上網線

#### 5.3.1 線孔位置

支撐板②和過線片①的標準距離是4.4mm。放鬆螺絲③再上下調整移動線孔。(Fig.42)

- 增加線量時，將過線片①往下移。
- 減少線量時，將過線片①往上移。

#### 5.3.2 調整上網線的時機

當大的上勾針④勾到小勾針上的線時(Fig.43)，網線和凸輪的尖端距離為0-1.0mm之間，調整凸輪⑤時鬆開螺絲⑥。(Fig.42)

註：調整好凸輪⑤時，勾線時間和凸輪⑤時間正確後，不必再前後調整。

#### 注意：

在調整機器之前，一定要先把電源關掉，並確定馬達完全停止。

### 5.3 Top cover thread tension

#### 5.3.1 Position of thread take-up eyelet

Make the standard distance from the top the eyelet supporting plate② to the thread take-up eyelet① eye to 4.4 mm. Loosen the screw③ and move the eyelet① up or down to adjust it.(Fig.42)

- To increase the top cover thread take-up amount, move the eyelet① downward.
- To decrease the top cover thread take-up amount, move the eyelet① upward.

#### 5.3.2 Timing of top cover thread take-up

The moment the top cover thread is hooked with the top cover thread hook④ (Fig. 45), the thread is held at the point 0-1.0 mm apart from the top of the take-up⑤. Loosen the screws⑥ to adjust it.(Fig.44)

#### Note :

When adjusting take-up⑤, face both bosses of the take-up⑤ and the looper thread take-up without shifting the front-and-rear position.

#### WARNING :

Before adjusting, always turn the motor switch OFF and check that the motor has already stopped.

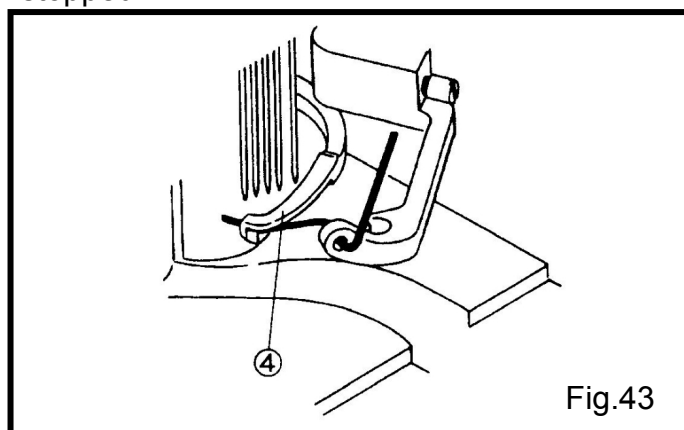
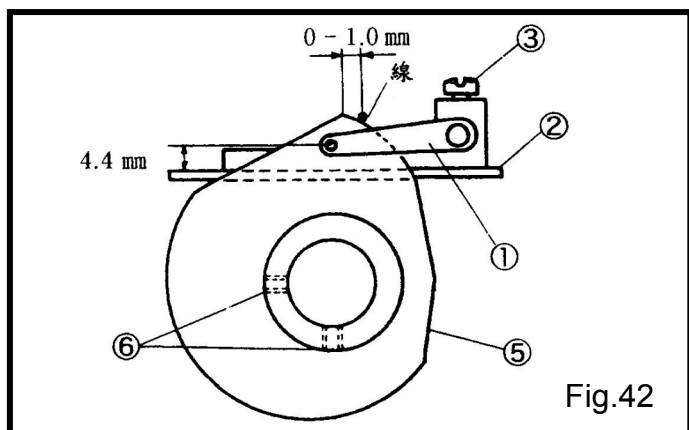

## 5 · Adjustments 調節裝置

### 5.4 針位高度

第四支針跟針板的距離為“N”的高度，但針距大小不同，高度就不同，如表格四所示。(Fig.44)

### 5.4 Height of needle

Make height “N” of the needle from the top of the stitch plate to the tip of the fourth needle from the left when the needle is at the highest point.(Fig.44)

針距 Needle distance	高度(N) Height(N)
R : 5.2mm	13.5mm
S : 6.0mm	12.7mm

表格四

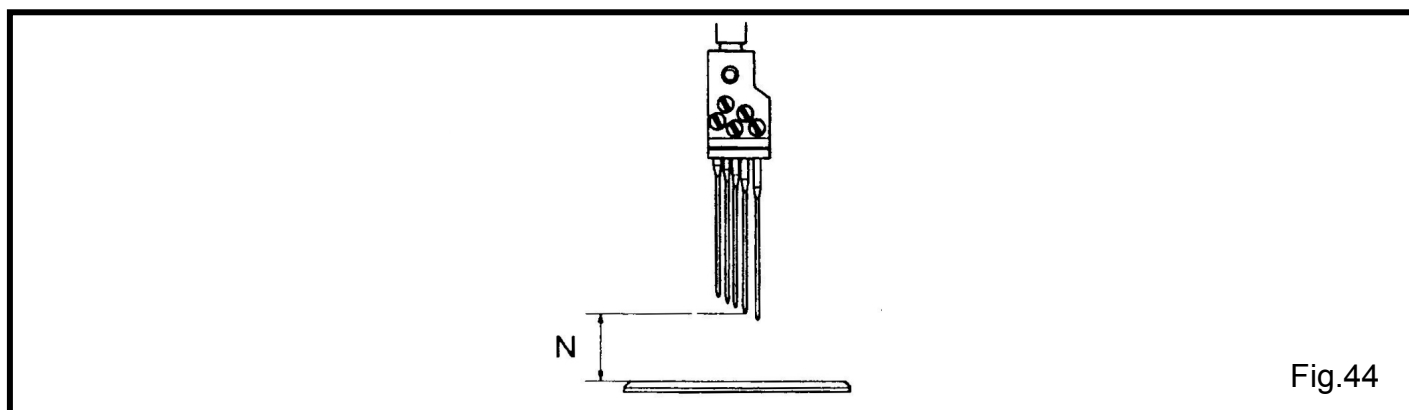

Fig.44

調整高度：

- (1) 移開油塞 ①。(Fig.45)
- (2) 鬆開螺絲 ②。
- (3) 上下移動針柱 ③ 去調整，針與針孔須保持平行。(Fig.46)
- (4) 鎖緊螺絲 ②。
- (5) 裝回油塞 ①。

Adjusting height :

- (1) Remove the seal plug ①.(Fig.45)
- (2) Loosen the screw ②.
- (3) Move the needle bar ③ up or down to adjust the height. Check the alignment.( Fig. 46.)
- (4) Tighten the screw ② screwruely.
- (5) Reset the seal plug ①.

注意：

在調整機器之前，一定要先把電源關掉，並確定馬達完全停止。

**WARNING :**

Before adjusting, always turn the motor switch OFF and check that the motor has already stopped.

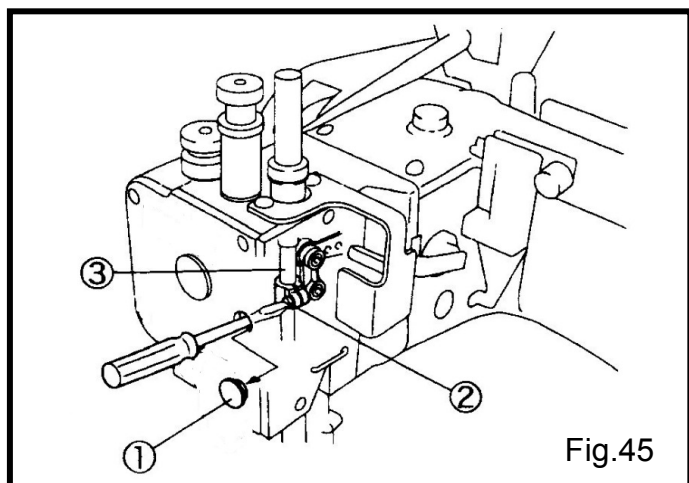

Fig.45

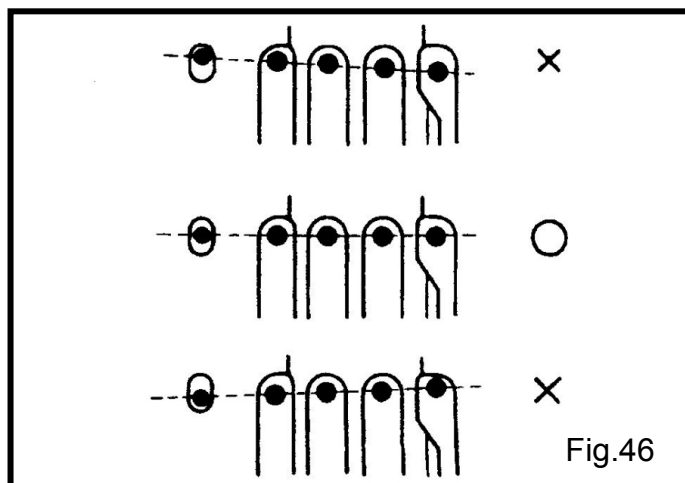

Fig.46

## 5 · Adjustments 調節裝置

### 5.5 上勾針

上網線的時間點：

調整上勾針的位置形成線圈，使第一針和第二針插入線圈內，放鬆螺絲⑤調整上勾針①。

(Fig.47)

上勾針：

當大上勾針②和小上勾針①最接近時的間隙為0.4-0.7mm。(Fig.48)

當大上勾針②停在最右邊時，和假針③要有0.5mm的間隙。(Fig.50)

放鬆螺絲⑥去調整。(Fig.49)

註：要調整時不要抬壓腳的上下。

注意：

在調整機器之前，一定要先把電源關掉，並確定馬達完全停止。

### 5.5 Top cover thread carrier and hook

Top cover thread carrier :

Position the top cover thread carrier① so that top cover thread loop formed with the hook behind the first and the second needles from the left when the carrier① comes most nearly to the needle. Loosen the screw⑤ to adjust it.(Fig.47)

Top cover thread hook :

When the top cover thread hook② comes most nearly to the top cover thread carrier①, make the clearance between them to 0.4-0.7 mm during one rotation. (Fig.48)

When the hook② moves at the extreme right, make the clearance between the hook② and the retainer③ to 0.5 mm. (Fig.50)

Loosen the screw⑥ to adjust them. (Fig.49)

Note :

Be sure adjust them without play up and down.

### WARNING :

Before adjusting, always turn the motor switch OFF and check that the motor has already stopped.

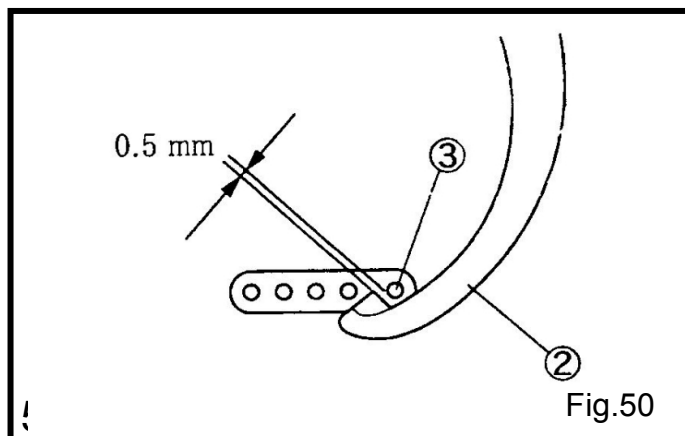
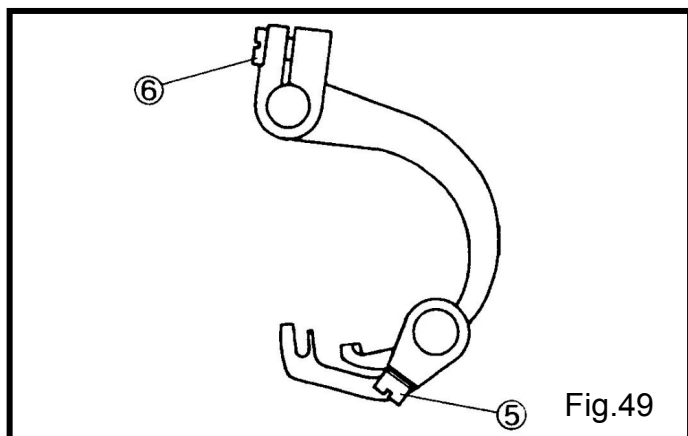
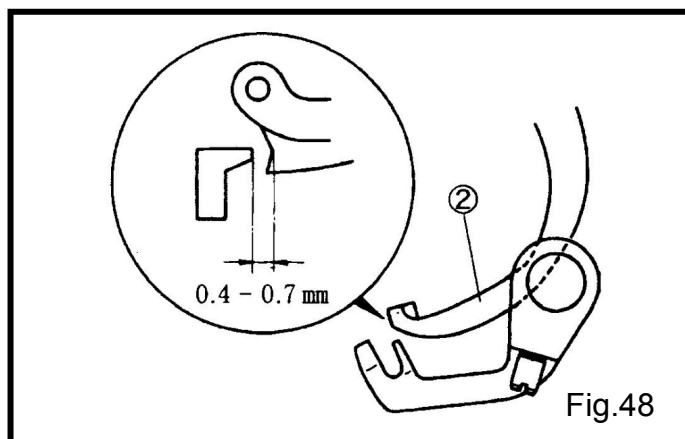
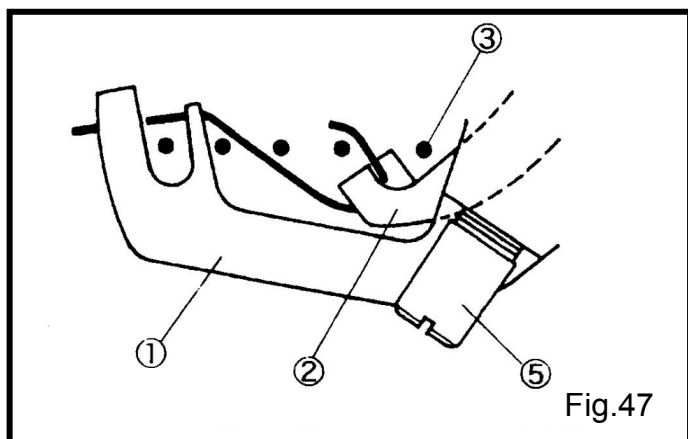



## 5 · Adjustments 調節裝置

高度：

裝下勾針①到下勾針座上⑥然後鎖緊螺②。

角度：

下勾針固定座平面A要和下勾針柱成90度。

放鬆螺絲②去調整下勾針。

下勾針和針的距離：

當下勾針在最左邊的時候，下勾針和針的標準距離為4.2-4.8mm。可放鬆螺絲④去調整。

下勾針的前後位置：

當下勾針①移動從左到右，會在針的後面。調整其位置使下勾針更接近針，其間隙0-0.05mm，但不能碰到針，當下勾針的尖端在左針的中間時，放鬆螺絲④轉動螺絲⑤調整前後位置。調整之後檢查間隙和鎖緊螺絲④。

- 順時間旋轉螺絲⑤會往前。
- 逆時間旋轉螺絲⑤會往後。

注意：

在調整機器之前，一定要先把電源關掉，並確定馬達完全停止。

### 5.6 Loper

Height :

Insert the looper① into the hole of the looper holder⑥ and tighten the screw② securely.

Angle :

Fix the surface A of the looper at 90° to the looper rocker shaft. Loosen the screw② to adjust it.

Distance between looper and needle :

Make standard distance between the looper tip and the center of the left needle to 4.2-4.8 mm when the looper① is at the extreme left. Loosen the screw④ to adjust it.

Front-and-rear position of looper and needle:

When the looper① moves from the left to the right, it passes behind the needle. Adjust the position so that the looper comes closely to the needle with the clearance of 0-0.05 mm but without touching them when the looper tip comes at the center of the left needle. Loosen the screw④ and turn the adjusting screw⑤ to adjust it. After adjusting, check the distance and tighten the screw④ securely.

- To move forward, turn the screw⑤ clockwise.
- To move backward, turn the screw⑤ counterclockwise.

**WARNING :**

Before adjusting, always turn the motor switch OFF and check that the motor has already stopped.

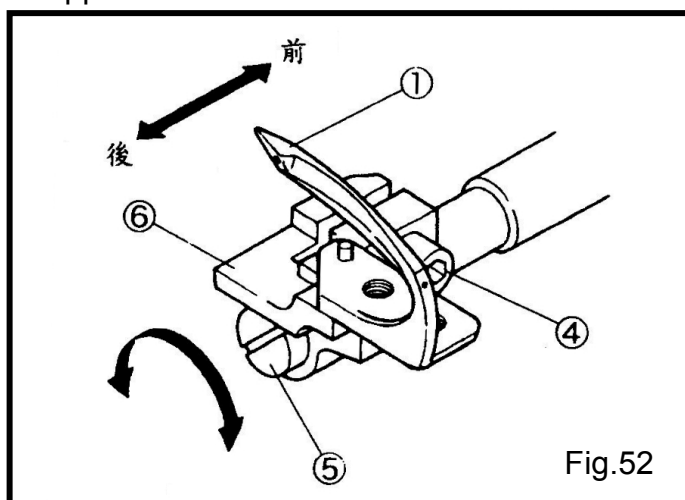
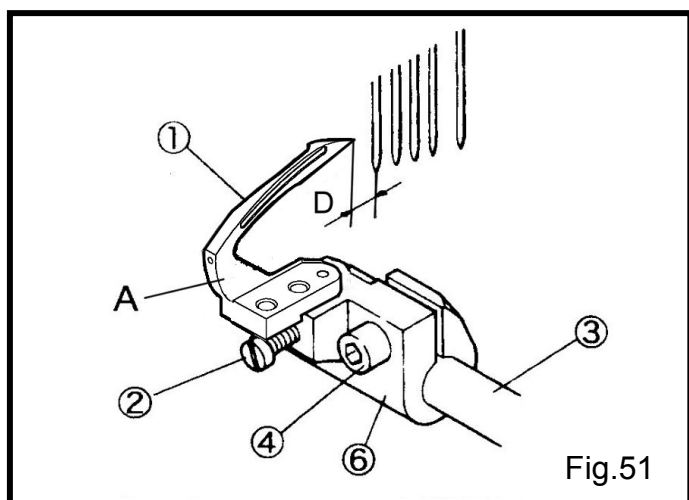

## 5 · Adjustments 調節裝置

### 5.7 前針檔

當針在左針中間時，推前針檔①，使針和下勾針的間隙為 0mm。放鬆螺絲②去調整它。當下勾針左移到右時，檢查下勾針③有無碰到針的後面，看針有無左右移動。(Fig.53,54)

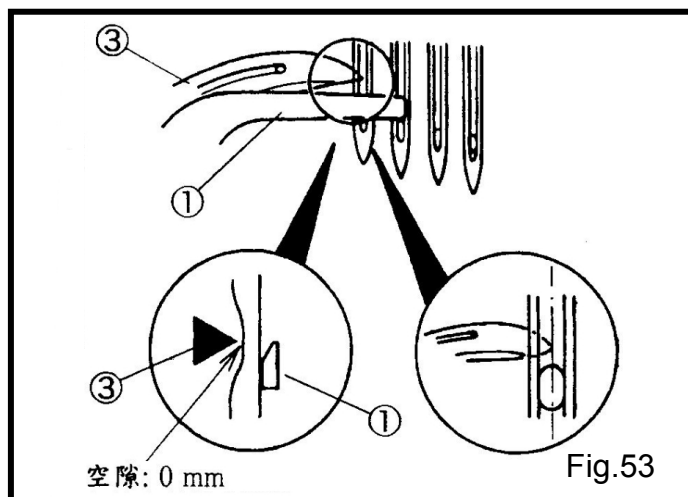

### 5.7 Needle guard (front)

Push the needle guard(front) ① so that the clearance between the needle and the looper is 0 mm when the looper tip comes at the center of the left needle. Loosen the screw② to adjust it. Check the looper tip touches the back of the needle and the does not swing to the right when the looper③ moves from the left to the right while rotating the handwheel. (Fig.53,54)

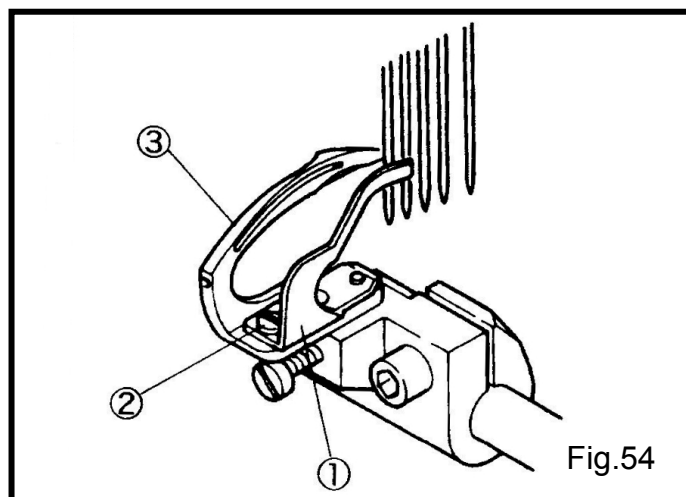

### 5.8 後針檔

當後針檔④和針最靠近的時候，要有 0.05-0.1mm 的間隙。由螺絲⑤去調整。(Fig.55)  
當下勾針從左移到右時，後針檔不能碰到針。

注意：

當有調整針距時，注意後針檔要重新整調。

注意：

在調整機器之前，一定要先把電源關掉，並確定馬達完全停止。

### 5.8 Needle guard(rear)

Make the standard clearance between the needle guard (rear) ④ and the left needle to 0.05-0.1 mm when they meet most closely. Open the looper cover and loosen the screw⑤ to adjust it. (Fig.55)

Check the needle does not swing to the right while rotating the handwheel.

#### CAUTION :

After changing stitch length, the clearance changes between the needle guard(rear) set on the main feed dog and the needle.

Readjust the position of the needle guard(rear) after changing stitch length.

#### WARNING :

Before adjusting, always turn the motor stitch OFF and check that the motor has already stopped.

## 5 · Adjustments 調節裝置

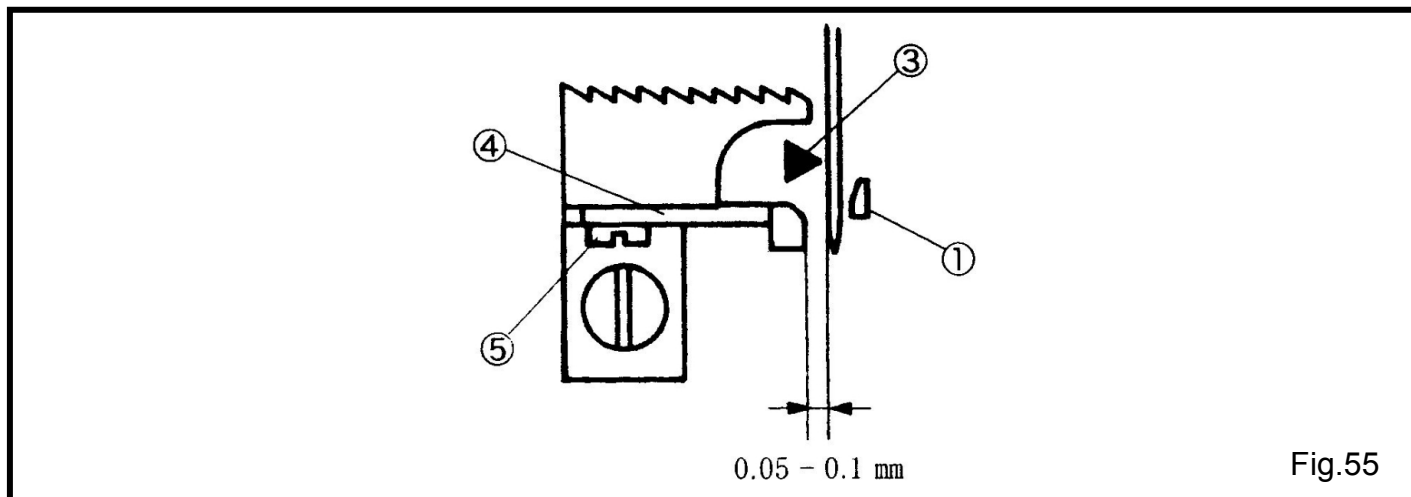

### 5.9 狗齒高度

安裝：

固定差動的狗齒和主要狗齒③用螺絲②和④固定後，針檔⑤在主要勾齒上調整時，鬆開螺絲⑥。(Fig.56)

高度：

當狗齒在最高點時，主狗齒③和針板的高度為1.2-1.5mm，前後狗齒必須保持一樣的高度。(Fig.57)

高度微調：

狗齒的高度後調要旋轉偏心銷⑧來控制。放鬆螺絲⑦然後調整偏心銷⑧的高低。(Fig.58)

- 順時針旋轉偏心銷⑧降低狗齒。
- 逆時針旋轉偏心銷⑧調高狗齒。

注意：

在調整機器之前，一定要先把電源關掉，並確定馬達完全停止。

### 5.9 Height of feed dog

Fixing :

Fix the differential feed dog① and main feed dog③ with the screw② and ④ respectively. Fix the needle guard(rear) ⑤ on the main feed dog and tighten it at the most rear position with the screw⑥ slightly. (Fig.56)

Height :

Adjust the height from the top of the stitch plate to the part A of the main feed dog③ to 1.2-1.5 mm when the feed dog is at the highest point. Align the differential feed dog even with the main feed dog. (Fig.57)

Fine adjustment of height :

Make fine adjustment of height of the main and differential feed dogs with the feed bar eccentric pin⑧ near the center of the cylinder. Loosen the screw⑦ and move the pin⑧ to adjust it.(Fig.58)

- To lower the feed dog, turn the pin⑧ clockwise.
- To raise the feed dog, turn the pin⑧ counterclockwise.

### WARNING

Before adjusting, always turn the motor stitch OFF and check that the motor has already stopped.

# 5 · Adjustments 調節裝置

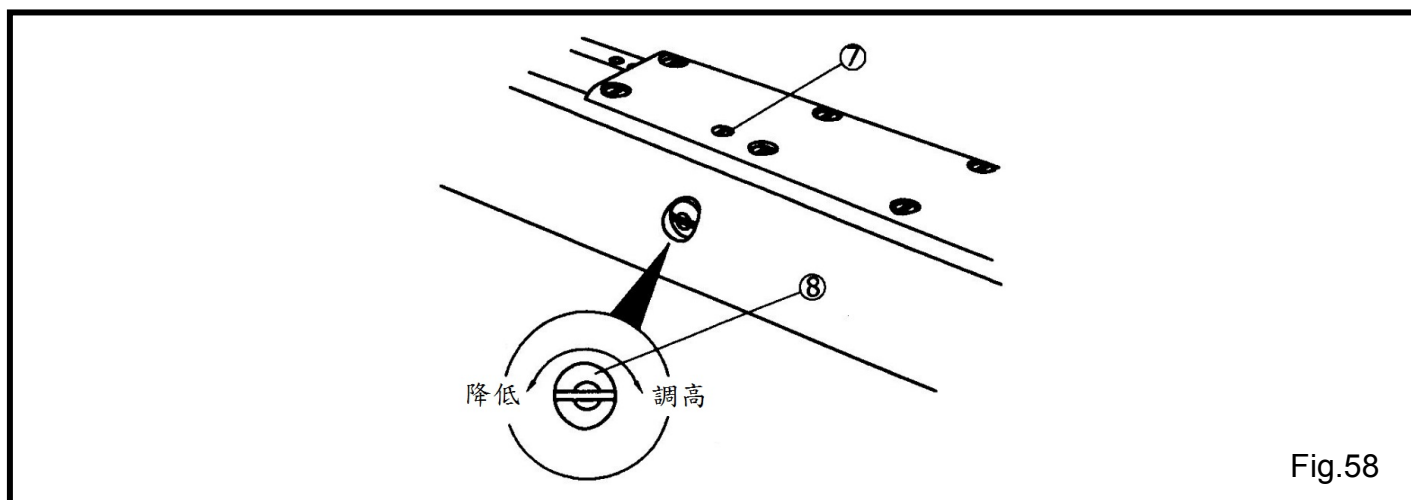
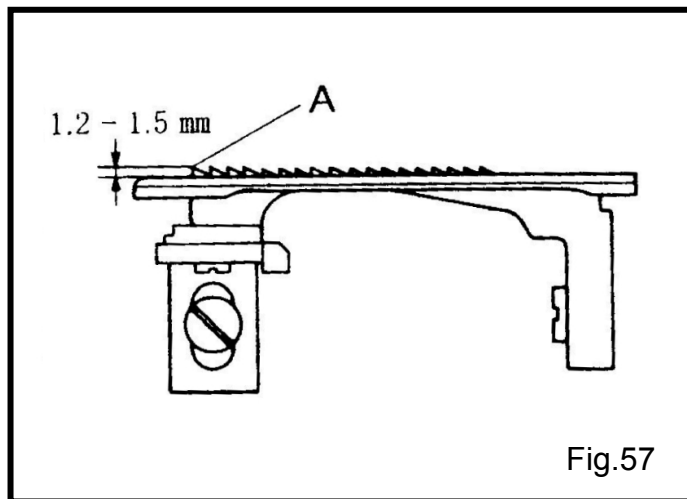
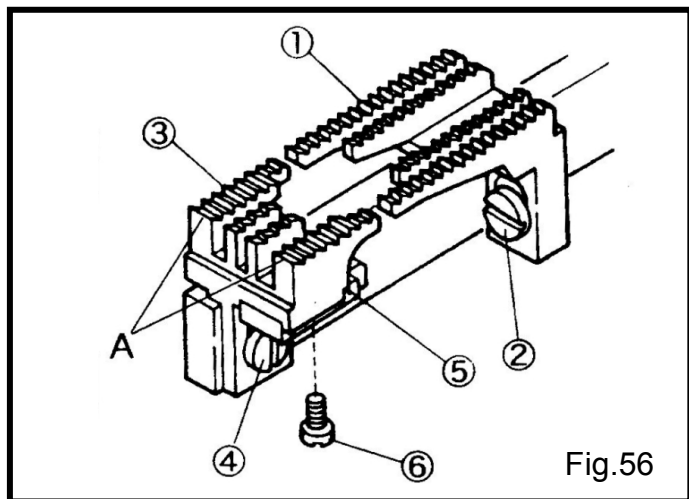

## 5 · Adjustments 調節裝置

### 5.10 置換壓腳

#### 5.10.1 拆除方法

- (1) 移開所有的針和油塞 ①。(Fig.59)
- (2) 放鬆調整螺帽 ② 然後才鬆開螺絲 ③。
- (3) 鬆開刀台的螺絲 ④ 讓整組刀架鬆開。(Fig.60)
- (4) 鬆開刀座連桿 ⑥ 的兩螺絲 ⑦，移除上刀座 ⑤ 和上刀。(Fig.61)
- (5) 放鬆壓腳螺絲 ⑧。
- (6) 將針轉到最高點，然後移除調整螺帽 ② 和抽出壓腳柱 ⑨ 和壓腳彈簧 ⑩。(Fig.62)
- (7) 推開上勾針驅動片 ⑪ 從帶動桿 ⑫ 脫離。(Fig.63)
- (8) 向左轉，拆下整組壓腳穿過左邊壓腳檔。

#### 注意：

在調整機器之前，一定要先把電源關掉，並確定馬達完全停止。

### 5.10 Replacing presser foot

#### 5.10.1 Removing :

- (1) Remove all needles and the seal plug ①.(Fig.59)
- (2) Loosen the adjusting screw ② and then the screw ③ of the presser bar connecting bracket.
- (3) Loosen the screws ④ of the knife holder guide collar to be free the complete set including the upper knife, the knife holder, and the knife holder shank. (Fig.60)
- (4) Loosen two screws ⑦ of the knife holder bracket ⑥ to remove the knife holder guide collar, c.set ⑤ and the upper knife. (Fig.61)
- (5) Loosen the screw ⑧ on the back of the presser foot.
- (6) Rotate the handwheel to raise the needle at the highest point. Remove the adjusting screw ② and keep the presser bar ⑨ and the presser spring ⑩ upward as they come off from the presser foot. (Fig.62)
- (7) Remove the carrier/hook driving segment ⑪ from the lever ⑫ on the carrier/hook driving sleeve. (Fig.63)
- (8) Turn the presser foot, c.set to the left and remove it through the presser foot guides(left)and(right).

#### WARNING :

Before adjusting, always turn the motor stitch OFF and check that the motor has already stopped.

# 5 · Adjustments 調節裝置

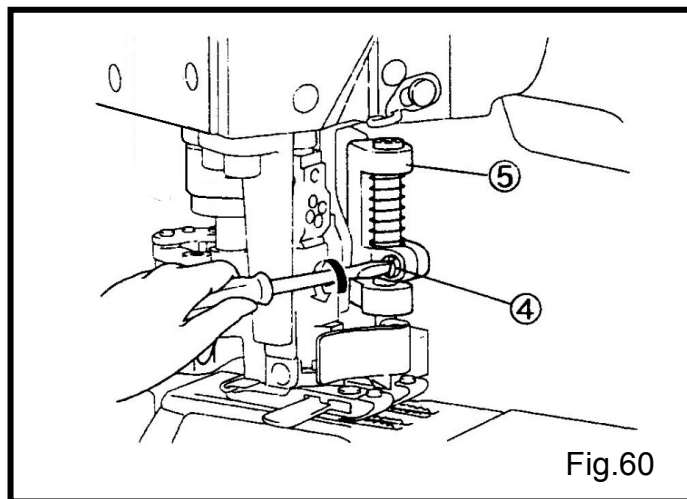
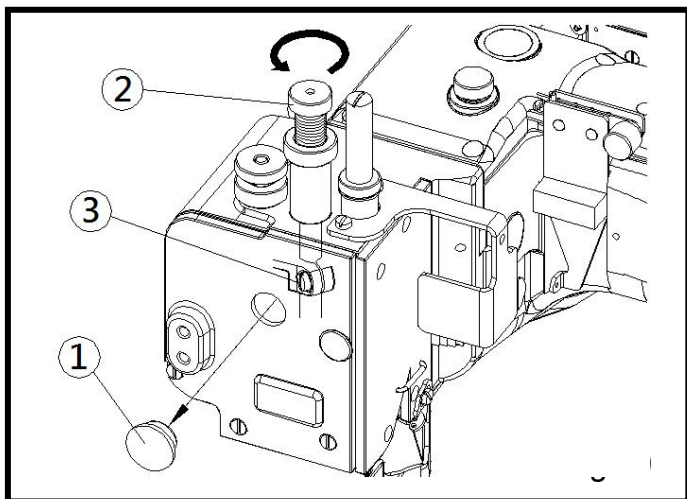

Fig.60

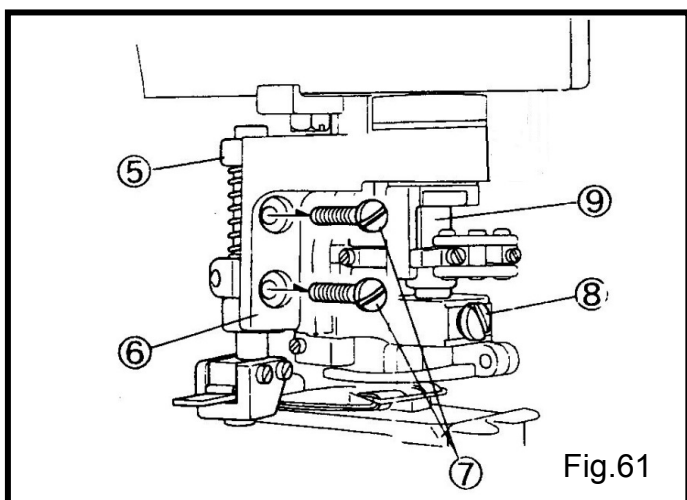

Fig.61

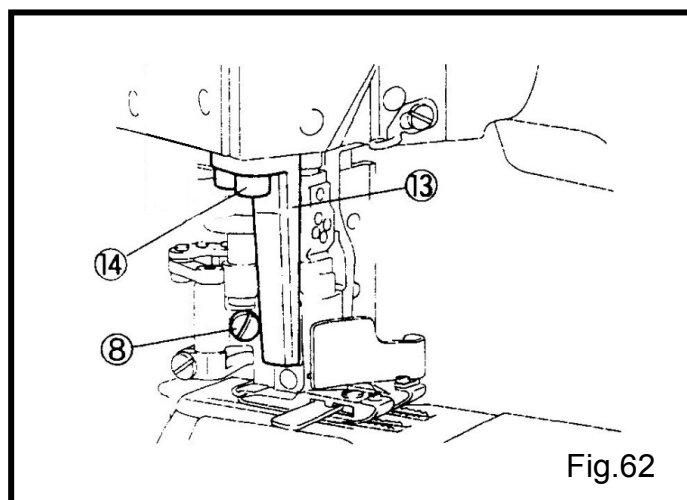

Fig.62

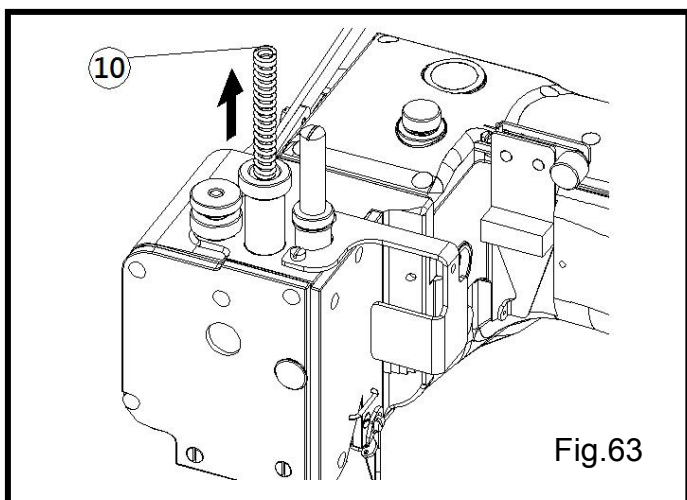

Fig.63

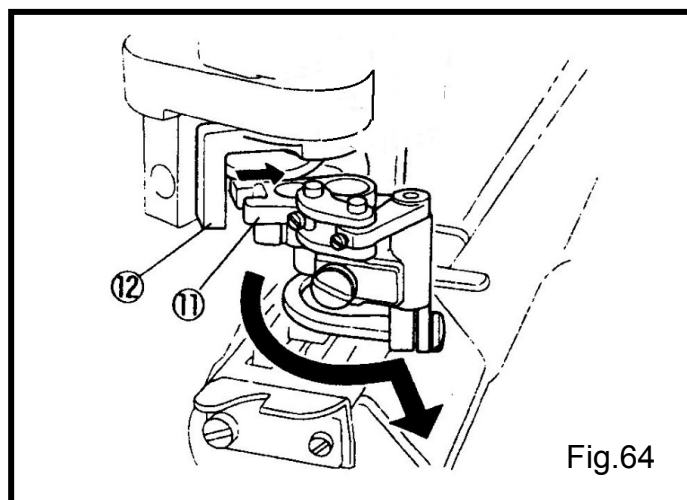

Fig.64

## 5 · Adjustments 調節裝置

### 5.10.2 組裝方法

- (1) 拆掉全部的針重新裝上壓腳在左右壓腳檔之間，向右旋轉，放正壓腳。
- (2) 重新裝上上勾針驅動片⑪到帶動桿⑫裡面。
- (3) 安裝壓腳柱插入上勾針驅動片⑪後鎖上壓腳後面的螺絲⑧。
- (4) 檢查壓腳是否順暢沒有左右晃動，如果有卡住，鬆開左壓腳檔⑬的螺絲⑭去調整。
- (5) 重新裝上刀台⑤固定在刀座⑥支撐架上。
- (6) 調整刀台和上刀的位置，當針在最低點的時候。
- (7) 當壓腳緊貼在針上和針在最低點時，重新裝上壓腳彈簧⑩及調整螺帽②，然後輕後的壓下螺絲③並鎖上。
- (8) 裝回油塞①。
- (9) 裝回所有的針。

#### 注意：

在調整機器之前，一定要先把電源關掉，並確定馬達完全停止。

### 5.10.2 Resetting :

- (1) Remove all needles, Reset the presser foot, c.set between the presser foot guides (left) and (right) while turning ti to the right diagonally from the back.
- (2) Reset the carrier/hook driving segment⑪ on the lever⑫ on the carrier/hook driving sleeve.
- (3) Insert the presser bar into the carrier/hook driving segment⑪ and tighten the screw ⑧ on the back of the presser foot.
- (4) Check the presser foot moves smoothly without play right and left. If not, loosen the screw⑭ of the presser foot guide(left) ⑬ to adjust it.
- (5) Reset the knife holder guide collar, c.set⑤ and the upper knife on the knife holder bracket⑥ with two screws.
- (6) Adjust the positions of the knife holder guide collar and the upper knife when the needle is at the lowest point.
- (7) Reset the adjusting screw② when the needle is at the lowest point and the presser foot touches closely on the stitch plate. Then tighten the screw③ of the presser bar connecting bracket while pushing slightly down.
- (8) Reset the seal plug①.
- (9) Reset all needles.

#### WARNING :

Before adjusting, always turn the motor stitch OFF and check that the motor has already stopped.

### 5.11 置換壓腳彈簧片

#### 5.11.1 拆除方法

- (1) 拆掉螺絲①。(Fig.65)
- (2) 拆掉壓腳彈簧片②。
- (3) 移開彈簧片勾③才能拿掉彈簧片②。

### 5.11 Replacing presser foot spring plate

#### 5.11.1 Removing:

- (1) Remove the screw①.(Fig.65)
- (2) Remove the presser foot sprint plates② from the presser foot.
- (3) Remove each plate② from the spring plate holder③.

## 5 · Adjustments 調節裝置

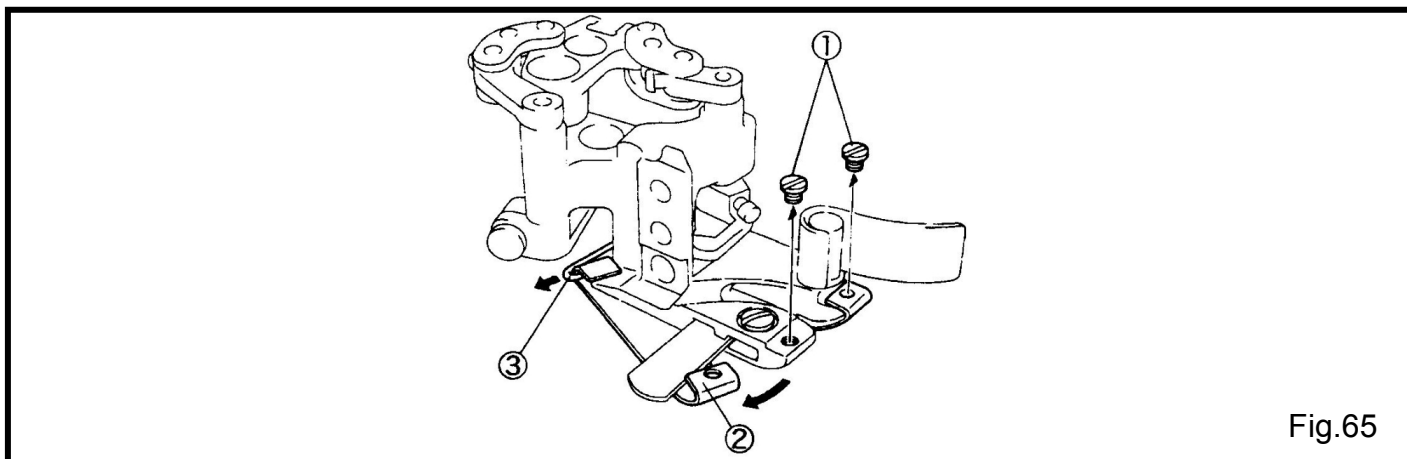

### 5.11.2 組裝方法

- (1) 重新裝上壓腳彈片 (2) 和壓腳彈片勾 (3)。  
(Fig.65)
- (2) 每片彈簧片 (2) 要對齊壓腳座。
- (3) 鎖上螺絲 (1)。

#### 注意：

在調整機器之前，一定要先把電源關掉，並確定馬達完全停止。

### 5.11.2 Resetting :

- (1) Reset each presser foot spring plate (2) with the spring plate holder (3). (Fig.65)
- (2) Reset the plates (2) parallel each other on the presser foot (2).
- (3) Tighten the screws (1) securely.

#### WARNING :

Before adjusting, always turn the motor switch OFF and check that the motor has already stopped.

## 5.12 置換和調整位置

### 5.12.1 上切刀的壓力

- (1) 當針在最高點，上切刀在左邊時壓腳要貼著針板上，上切刀 (1) 刀刃要貼合下切刀 (2) 的刀刃。(Fig.67)
- (2) 刀座 (3) 和壓力彈簧軸環 (4) 之間的標準間隙為 1.0mm。(Fig.66)
- (3) 鬆開螺絲 (5) 和移動軸環 (4) 調整壓力。

- 增加壓力往上移動彈簧軸環 (4)。
- 減少壓力往下移動彈簧軸環 (4)。

#### 註：

上刀 (1) 和下刀 (2) 成一直線時，上刀不能碰到壓腳壁，正確後固定彈簧軸環。(Fig.67)

## 5.12 Replacing and adjusting knives

### 5.12.1 Pressure of upper knife:

- (1) When the needle is at the highest point and the upper knife (1) is at the extreme left, the presser foot touches the stitch plate, and the upper knife (1) touches the lower knife (2) closely. (Fig.67)
  - (2) The standard clearance between the bearing of the knife holder shank support (3) and the knife holder guide collar (4) is 1.0 mm. (Fig.66)
  - (3) Loosen the screw (5) and move the knife holder guide collar (4) to adjust the pressure.
- To increase the pressure, move the collar (4) upward.
  - To decrease the pressure, move the collar (4) downward.

#### Note:

Align the front sides of the upper (1) and lower (2) knives without touching the upper knife to the presser foot. After check them, fix the knife holder guide collar (4) with the screw. (Fig.67)



## 5 · Adjustments 調節裝置

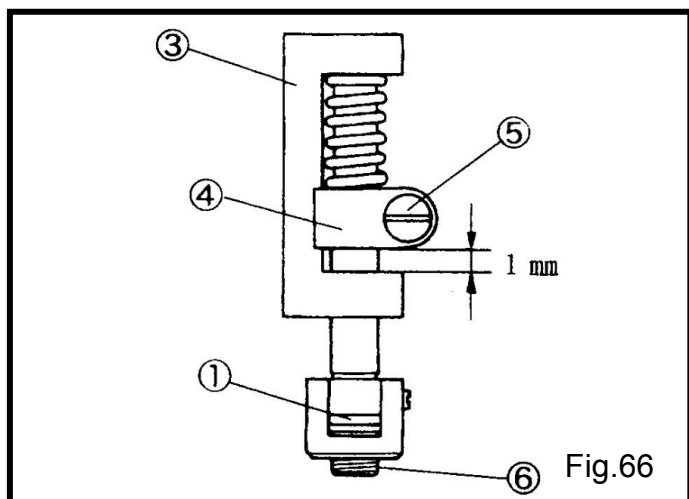

Fig.66

### 5.12.2 拆除方法

- (1) 放鬆螺絲 ⑤ 和 ⑥ 才能拆掉上切刀 ①。
- (2) 放鬆螺絲 ⑦ 才能拆掉下切刀 ②。

### 5.12.3 組裝方法

- (1) 重新安裝下切刀 ② 要鎖緊螺絲 ⑦。
- (2) 重新安裝上切刀 ① 要鎖緊螺絲 ⑥。

### 5.12.4 上切刀角度之調整

- (1) 拆掉 ①-⑤ 的部份，以螺絲 ⑥ 去調整刀的角度。
- (2) 重新安裝時要注意插銷 ⑦ 有無對準刀座 ⑧ 上的孔。

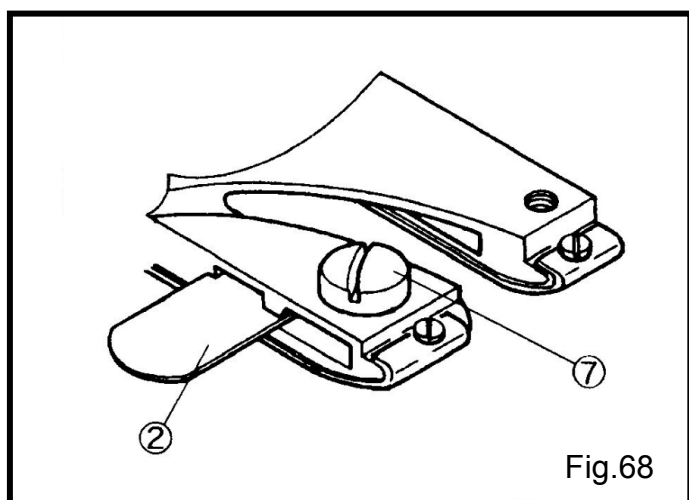

Fig.68

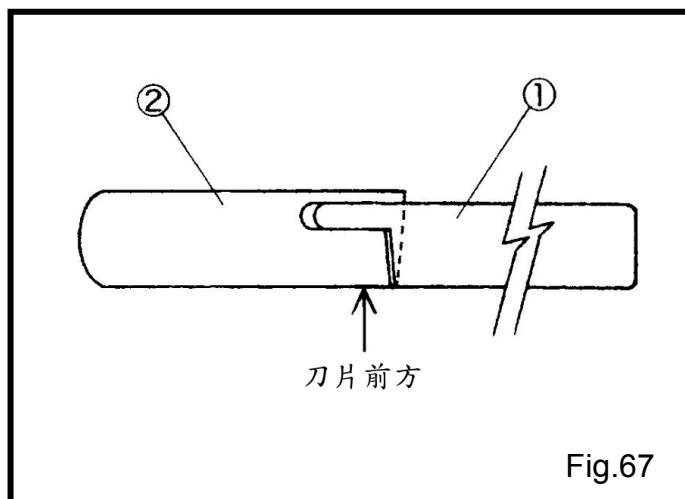

Fig.67

### 5.12.2 Removing :

- (1) Loosen the screws ⑤ and ⑥ to remove the upper knife ①.
- (2) Loosen the screw ⑦ to remove the lower knife ②.

### 5.12.3 Resetting :

- (1) Reset the lower knife ② with the screw ⑦.
  - (2) Reset the upper knife ① with the screw ⑥.
- See "5.9 Adjusting lapped width of upper fabric" for engagement of the knives.

### 5.12.4 Engaging angle of upper knife to lower knife

- (1) Remove the parts ①-⑤ in the order and turn the screw ⑥ to adjust it.
- (2) When resetting, check the screw ⑦ is not out from the bottom of the knife support ⑤. Then insert it into the bracket hole ⑧ to tighten.

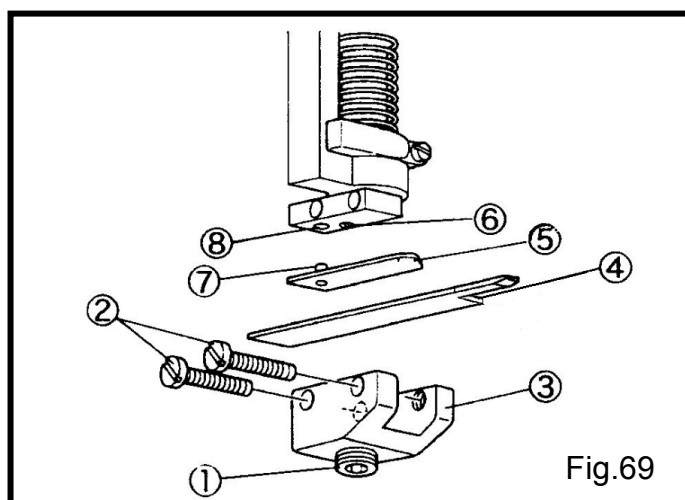

Fig.69

## 6 · Specifications 規格

機型	MU62D
說明	曲臂型四針六線拼縫機
體積	長 420mm x 寬 300mm x 高 410mm
圓週	針棒下線最小圓週 148mm
工作空間	圓週 210mm
重量	23 公斤 ( 頭部 )
車縫速度	最高 4200 R.P.M. ； 普通 2800 R.P.M.
縫距	1.6-2.5mm 每英寸 10-16 針；每 30mm 12-19 針
針型	車針：Organ FLX118GCS ； Groz-Beckert UY118GKS 假針：Organ FLG-1 , FLF-8 ； Groz-Beckert 36211 , 36211A
針距	R：5.2mm S：6.0mm
抬壓腳	單切：最大 8mm 雙切：最大 6mm
送料方式	桿槓原理
差動比	一般差動比：1.0：1.5 反差動比：1.0：0.7
差動送料規則	轉盤
切布刀	特殊鋼材製造
潤滑	自動齒輪幫浦
潤滑油	TELLUS 46
油槽容量	框：約 100cc 筒：約 100cc